

| CATALOG NO. | T SLOTS REQ | L | A |
|-------------|-------------|--------|--------|
| J5124 | 8 | 15.000 | 13.500 |
| J5109 | 9 | 16.500 | 15.000 |
| J5125 | 14 | 24.000 | 22.500 |
| J5126 | 18 | 30.000 | 28.500 |

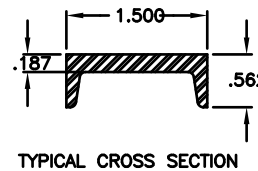
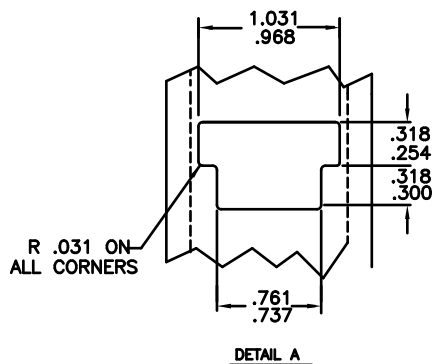

MATERIAL:

HOT ROLLED CARBON STEEL CHANNEL (ASTM A-36)

NOTES:

- 1) ALL DIMENSIONS ARE IN INCHES, EXCEPT AS NOTED
- 2) HOT DIP GALVANIZED (ASTM A-153)

PER BELL SYSTEM SPEC. CA06784

| UNSPECIFIED DIMENSIONAL TOLERANCES | | DATE | | CATALOG NO. | |
|--------------------------------------------------------------------------------------------------------------------------------------------------------------------------------------------------------------------------------------------------------------------------------------------------------------------------------------------------------------------------------------------|-----------------------|---------------|-----|-------------|------|
| FRACTIONAL ± | DECIMAL ± .031 | ANGULAR ± | NO. | REVISION | DATE |
| | | | | | |
| 2 | ADDED J5109 TO TABLE | 8-30-94 | GB | | |
| 1 | SEE E. C. N. NO. C626 | 1-14-94 | GB | | |
| SUPERSEDES: DWG NO. 1272 DATED 3-17-77 | | | | | |
| THIS DRAWING IS THE PROPERTY OF JOSLYN MANUFACTURING CO. AND EMBODIES A CONFIDENTIAL PROPRIETARY DESIGN IN WHICH JOSLYN RETAINS ALL PATENTS AND PROPRIETARY RIGHTS INCLUDING EXCLUSIVE RIGHT OF USE, MANUFACTURE AND SALE. BY ACCEPTING THIS DRAWING, THE RECIPIENT AGREES NOT TO DISCLOSE, REPRODUCE OR USE ANY INFORMATION CONTAINED HEREIN WITHOUT THE PRIOR WRITTEN CONSENT OF JOSLYN. | | | | | |
| DATE 1-14-94 | | DWG. NO. 1272 | | DRAWN JB | |
| CHECKED | | SCALE: | | SHEET 10F 1 | |

CATALOG NO.

JOSLYN
MANUFACTURING CO.

UNDERGROUND CABLE RACKS

DATE 1-14-94 DWG. NO. 1272

CHECKED SCALE: SHEET 10F 1