

COMPONENT SPECIFICATION

USE OR REPRODUCTION OF THIS DRAWING FOR THE PURPOSE OF MANUFACTURING THIS ARTICLE OR ANY ARTICLES SHOWN FOR ANY PURPOSE IS STRICTLY PROHIBITED WITHOUT WRITTEN PERMISSION FROM SENIOR INDUSTRIES, INC.

SPECIFICATIONS

ELECTRICAL:

CONTACT RATING: 300 mA @ 125 VAC  
 CONTACT RESISTANCE: 20 MILLIOHMS MAX.  
 INSULATION RESISTANCE: 100 MEGOHMS MIN. @ 500 VDC  
 DIELECTRIC STRENGTH: 500 V RMS

MECHANICAL:

LIFE: 15,000 CYCLES  
 ACTUATION FORCE: 400 ±150 GRAMS

MATERIAL:

ACTUATOR: PBT, UL94V-0  
 HOUSING: STEEL, TIN PLATED  
 CONTACTS: PHOSPHOR BRONZE  
 TERMINALS: BRASS  
 PLATING: CONTACT AREA - GOLD OR SILVER OVER NICKEL  
 TERMINATION AREA - TIN OVER NICKEL.

ENVIRONMENTAL:

OPERATING TEMPERATURE: -40°C TO +85°C

NOTE: 'X' IN PART NUMBER DENOTES PLATING:  
 1 - SILVER PLATING  
 3 - GOLD PLATING



**SENIOR INDUSTRIES, INC.**

TELECOM GRADE

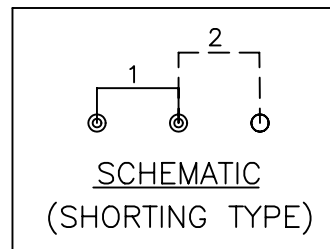
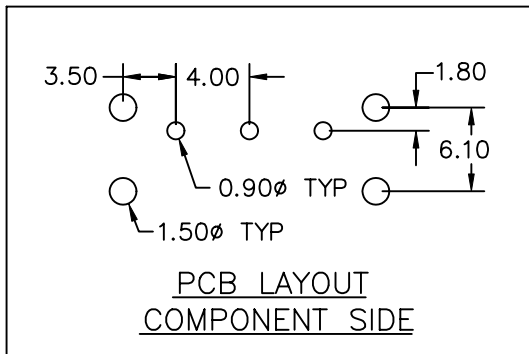
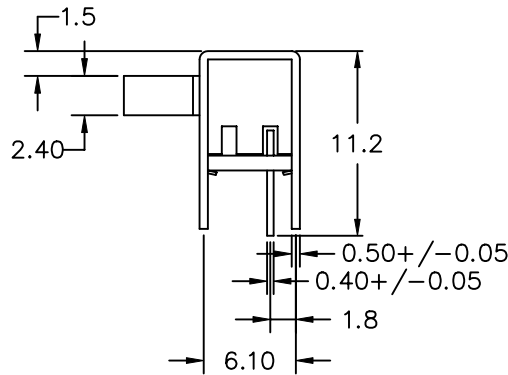
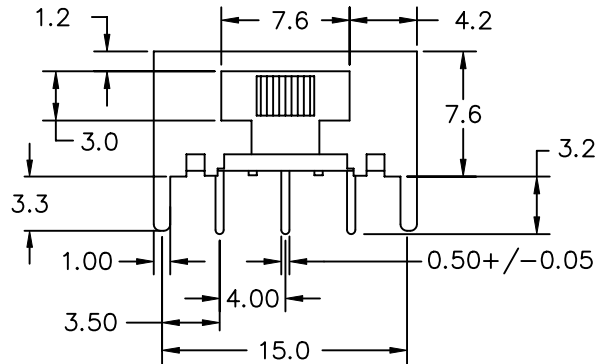
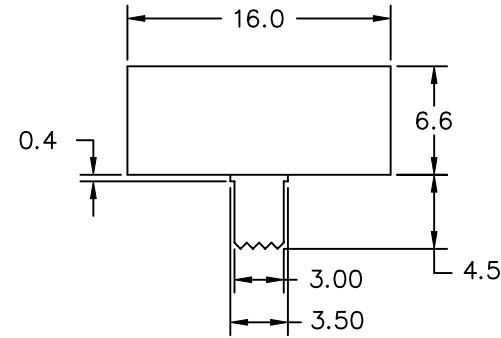

DESIGNED:			SYM.	DATE:	DESCRIPTION OF REVISIONS:	DRAWN:	APPD:	TOLERANCE:	PART NO:	12HH2RX
DRAWN:	TSF	11/28/98	▲	08.24.99	Dwg transfered to CAD format	RB	JF	TO 1 DECIMAL PLACE: ±.2	TITLE:	SLIDE SWITCH
CHECKED:	GAT	09/09/05	▲	09.09.05	New Index, Spec added, Notes updated	GAT	JF		TO 2 DECIMAL PLACES: ±.10	SHEET:
APPROVED:	JF	11/03/05	▲					AS ANGLES: ± °		
3RD ANGLE		UNIT:	mm	SCALE:	2:1	REV.	D			