

COMPONENT SPECIFICATION

USE OR REPRODUCTION OF THIS DRAWING FOR THE PURPOSE OF MANUFACTURING THIS ARTICLE OR ANY ARTICLES SHOWN FOR ANY PURPOSE IS STRICTLY PROHIBITED WITHOUT WRITTEN PERMISSION FROM SENIOR INDUSTRIES, INC.

SPECIFICATIONS

ELECTRICAL:

CONTACT RATING: 300 mA @ 125 VAC  
 CONTACT RESISTANCE: 20 MILLIOHMS MAX.  
 INSULATION RESISTANCE: 100 MEGOHMS MIN. @ 500 VDC  
 DIELECTRIC STRENGTH: 500 V RMS

MECHANICAL:

LIFE: 15,000 CYCLES  
 ACTUATION FORCE: 400 ±150 GRAMS

MATERIAL:

ACTUATOR: PBT, UL94V-0  
 HOUSING: STEEL, TIN PLATED  
 CONTACTS: PHOSPHOR BRONZE  
 TERMINALS: BRASS  
 PLATING: CONTACT AREA - GOLD OR SILVER OVER NICKEL  
 TERMINATION AREA - TIN OVER NICKEL.

ENVIRONMENTAL:

OPERATING TEMPERATURE: -40°C TO +85°C

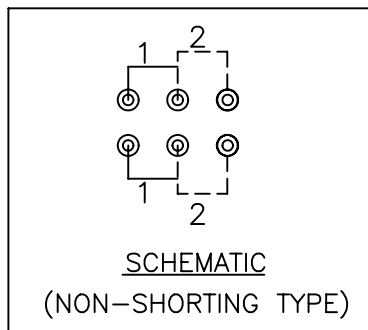
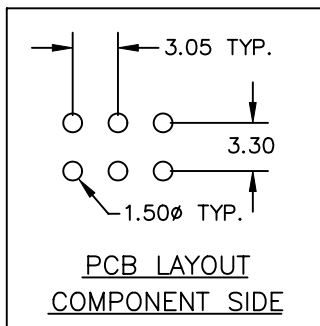
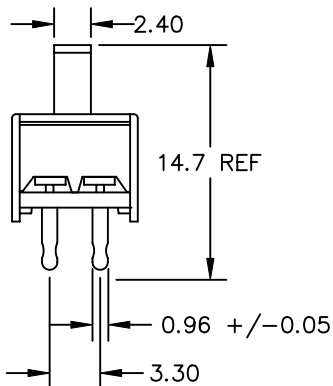
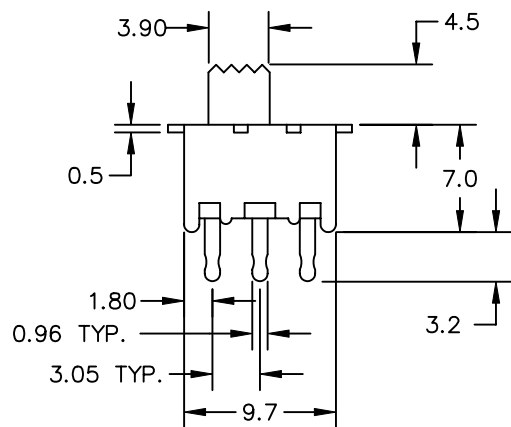
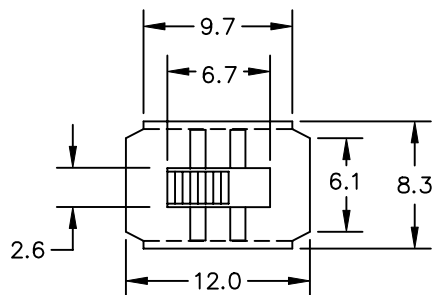

NOTE: 'X' IN PART NUMBER DENOTES PLATING:  
 1 - SILVER PLATING  
 3 - GOLD PLATING

TELECOM GRADE



**SENIOR INDUSTRIES, INC.**

DESIGNED:			SYM.	DATE:	DESCRIPTION OF REVISIONS:	DRAWN:	APPD:	TOLERANCE:	PART NO:	22SL4UX
DRAWN:	TSF	12/01/98	▲	08.23.99	Transfer original drawing to CAD format	RB	JF			
CHECKED:	GAT	11/01/05	▲	.	.			AS ANGLES: ±1/2°	SHEET:	1 OF 1
APPROVED:	JF	11/04/05	▲	.	.					
3RD ANGLE		UNIT:	mm	SCALE:	2:1	REV.	D			