

COMPONENT SPECIFICATION

USE OR REPRODUCTION OF THIS DRAWING FOR THE PURPOSE OF MANUFACTURING THIS ARTICLE OR ANY ARTICLES SHOWN FOR ANY PURPOSE IS STRICTLY PROHIBITED WITHOUT WRITTEN PERMISSION FROM SENIOR INDUSTRIES, INC.

SPECIFICATIONS

ELECTRICAL:

CONTACT RATING: 300 mA @ 125 VAC
 CONTACT RESISTANCE: 20 MILLIOHMS MAX.
 INSULATION RESISTANCE: 100 MEGOHMS MIN. @ 500 VDC
 DIELECTRIC STRENGTH: 500 V RMS

MECHANICAL:

LIFE: 15,000 CYCLES
 ACTUATION FORCE: 400 ±150 GRAMS

MATERIAL:

ACTUATOR: PBT, UL94V-0
 HOUSING: STEEL, TIN PLATED
 CONTACTS: PHOSPHOR BRONZE
 TERMINALS: BRASS
 PLATING: CONTACT AREA - GOLD OR SILVER OVER NICKEL
 TERMINATION AREA - TIN OVER NICKEL.

ENVIRONMENTAL:

OPERATING TEMPERATURE: -40°C TO +85°C

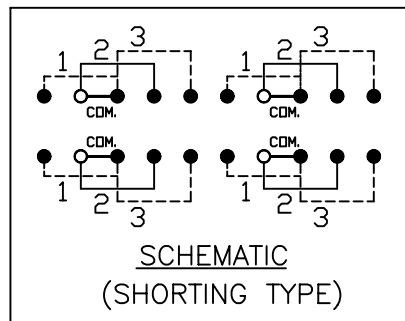
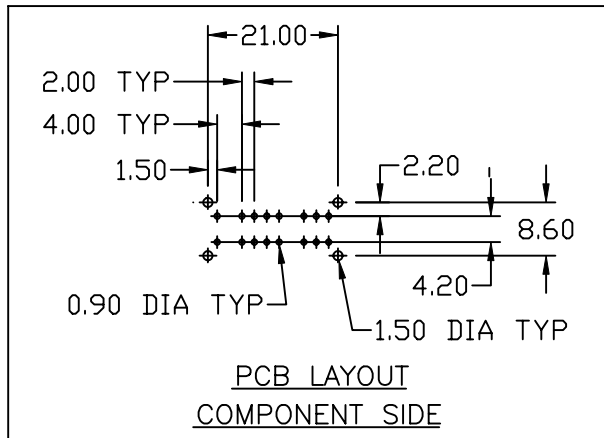
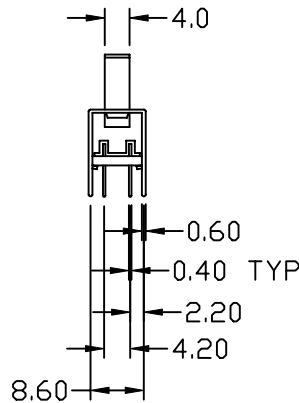
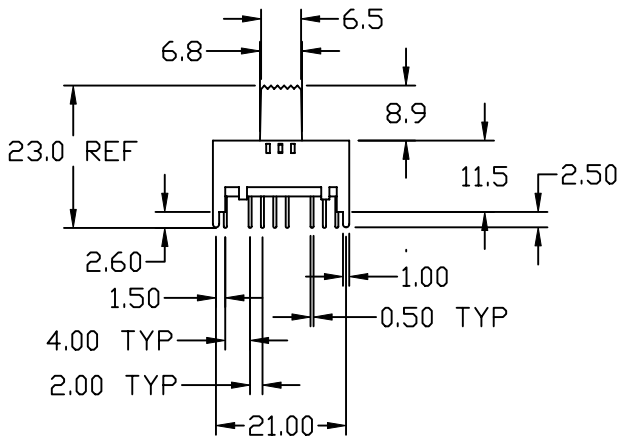
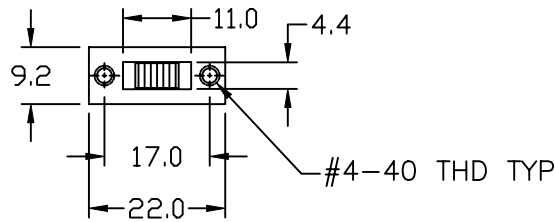

NOTE: 'X' IN PART NUMBER DENOTES PLATING:
 1 - SILVER PLATING
 3 - GOLD PLATING

TELECOM GRADE



SENIOR INDUSTRIES, INC.

DESIGNED:			SYM.	DATE:	DESCRIPTION OF REVISIONS:	DRAWN:	APPD:	TOLERANCE:	PART NO:	43MS3UX
DRAWN:	TSF	01/31/99	▲	02.02.99	Transfer original drawing into CAD format	TF	JF	TO 1 DECIMAL PLACE: ±.2 TO 2 DECIMAL PLACES: ±.10	TITLE:	SLIDE SWITCH
CHECKED:	GAT	11/29/05	▲	08.31.05	New Index, Spec Updates, Notes Corrected	KO	JF		SHEET:	1 OF 1
APPROVED:	JF	11/29/05	▲					AS ANGLES:	±1/2°	
3RD ANGLE			UNIT:	mm	SCALE:	1:1	REV.	C		