

1

2

3

4

5

COMPONENT SPECIFICATION

USE OR REPRODUCTION OF THIS DRAWING FOR THE PURPOSE OF MANUFACTURING THIS ARTICLE OR ANY ARTICLES SHOWN FOR ANY PURPOSE IS STRICTLY PROHIBITED WITHOUT WRITTEN PERMISSION FROM SENIOR INDUSTRIES, INC.

SPECIFICATIONS

ELECTRICAL:

CONTACT RATING: 300 mA @ 125 VAC
CONTACT RESISTANCE: 20 MILLIOHMS MAX.
INSULATION RESISTANCE: 100 MEGOHMS MIN. @ 500 VDC
DIELECTRIC STRENGTH: 500 V RMS

MECHANICAL:

LIFE: 15,000 CYCLES
ACTUATION FORCE: 400 ±150 GRAMS

MATERIAL:

ACTUATOR: PBT, UL94V-0
HOUSING: STEEL, TIN PLATED
CONTACTS: PHOSPHOR BRONZE
TERMINALS: BRASS
PLATING: CONTACT AREA - GOLD OR SILVER OVER NICKEL
TERMINATION AREA - TIN OVER NICKEL.

ENVIRONMENTAL:

OPERATING TEMPERATURE: -40°C TO +85°C

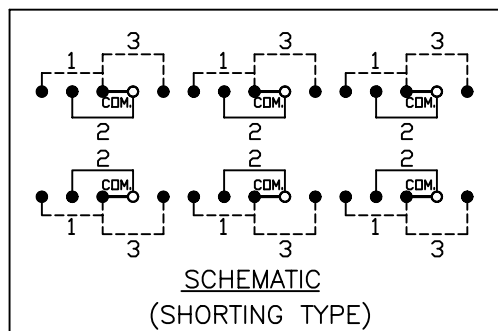
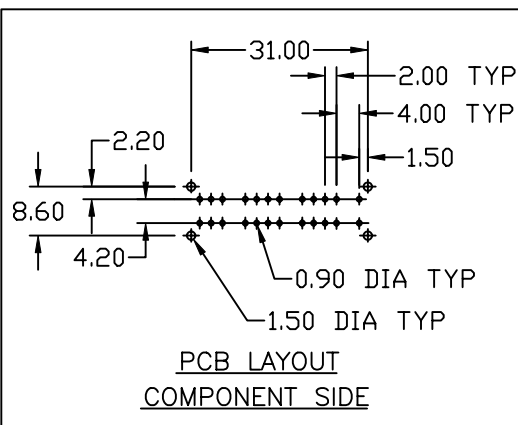
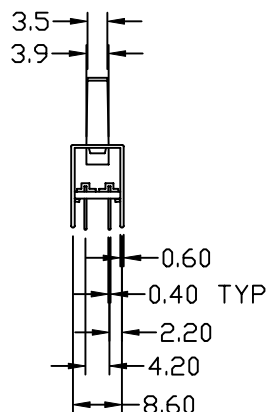
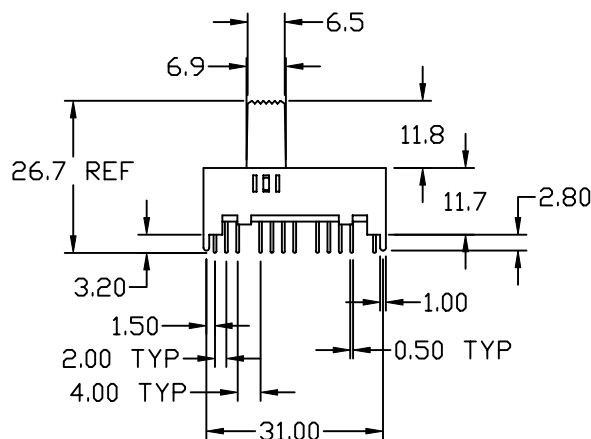
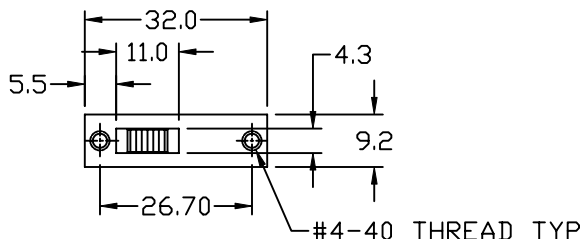

NOTE: 'X' IN PART NUMBER DENOTES PLATING:
1 - SILVER PLATING
3 - GOLD PLATING

TELECOM GRADE



SENIOR INDUSTRIES, INC.

Table with columns: DESIGNED, DRAWN, CHECKED, APPROVED, SYM, DATE, DESCRIPTION OF REVISIONS, DRAWN, APPD.

Table with columns: TOLERANCE, PART NO, TITLE, SHEET, and values: TO 1 DECIMAL PLACE: ±.2, TO 2 DECIMAL PLACES: ±.10, AS ANGLES: ±1/2°, PART NO: 63MS2UX, TITLE: SLIDE SWITCH, SHEET: 1 OF 1

Table with columns: 3RD ANGLE, UNIT, mm, SCALE, 1:1, REV., C