

COMPONENT SPECIFICATION

USE OR REPRODUCTION OF THIS DRAWING FOR THE PURPOSE OF MANUFACTURING THIS ARTICLE OR ANY ARTICLES SHOWN FOR ANY PURPOSE IS STRICTLY PROHIBITED WITHOUT WRITTEN PERMISSION FROM SENIOR INDUSTRIES, INC.

SPECIFICATIONS

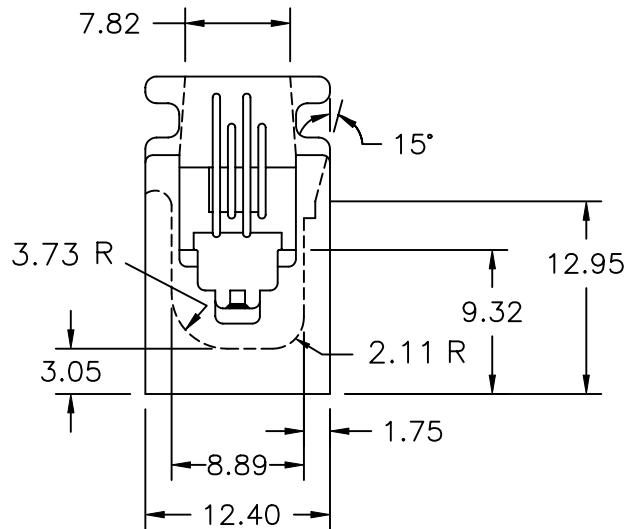
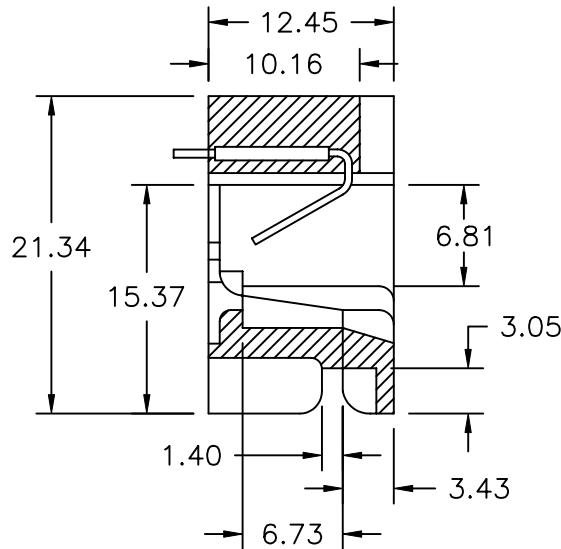
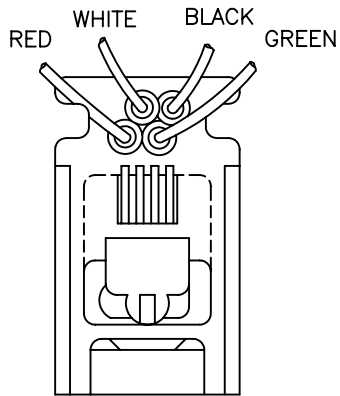

ELECTRICAL:

CONTACT RATING: 1.5A AT 125 VAC
 CONTACT RESISTANCE: 30 MILLIOHMS MAX.
 INSULATION RESISTANCE: 500 MEGOHMS MIN. AT 500 VDC
 DIELECTRIC STRENGTH: 500 VRMS FOR 1 MINUTE

MECHANICAL:

CRIMP TENSILE STRENGTH: 2.3 Kg MIN.

MATERIAL:

HOUSING: ABS, UL94V-0
 CONTACT: 0.46mm PHOSPHOR BRONZE, GOLD OVER NICKEL
 SHORTING BARS: 0.46mm PHOSPHOR BRONZE, GOLD OVER NICKEL
 TERMINAL: 0.4mm BRASS, 100 MICROINCHES TIN PLATING
 WIRE STYLE: UL1061 AWM 80°C, VW-1.300V, 26 AWG PVC INSULATION. TOP COATED UL1061 WIRE.

REGULATORY:

UL RECOGNIZED COMPONENT. UL FILE NO. E147880.

PART NUMBER BUILDER:

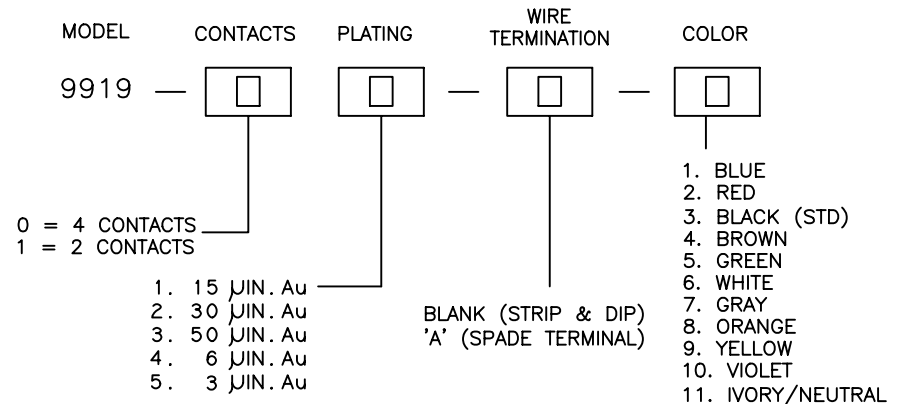

SENIOR INDUSTRIES, INC.

DESIGNED:			SYM.	DATE:	DESCRIPTION OF REVISIONS:	DRAWN:	APPD:	TOLERANCE:	PART NO:	9919-XX-X-X
DRAWN:	RJT	02/07/01	▲	03.14.01	NEW	RB	JF	TO 1 DECIMAL PLACE: ±.3 TO 2 DECIMAL PLACES: ±.15	TITLE:	MODULAR JACK
CHECKED:	GAT	02/23/06	▲	08.08.05	New Index, PN Builder Corrected, UL rating added	KO	JF			
APPROVED:	JF	02/23/06	▲					AS ANGLES:	SHEET:	1 OF 1
3RD ANGLE			UNIT:	mm	SCALE:	2:1	REV:	B		