

NOTES:

1. HOT DIP GALV. PER ASTM A123, AFTER FABRICATION.
2. TORQUE STRENGTH - 10,000 FT-LB (13,558 Nm).
3. 100,000 lbf [444,822 N] TENSION RATING.
4. 3in [7.5cm] HELIX PITCH.
5. NOMINAL SPACING BETWEEN HELICAL PLATES IS 3 TIMES THE SMALLER HELIX DIAMETER.
6. COUPLING BOLTS: 3/4" DIAMETER X 3" LONG HEX HEAD PER ASTM A325 AND 3/4" HEX JAM NUTS PER ASTM A563.

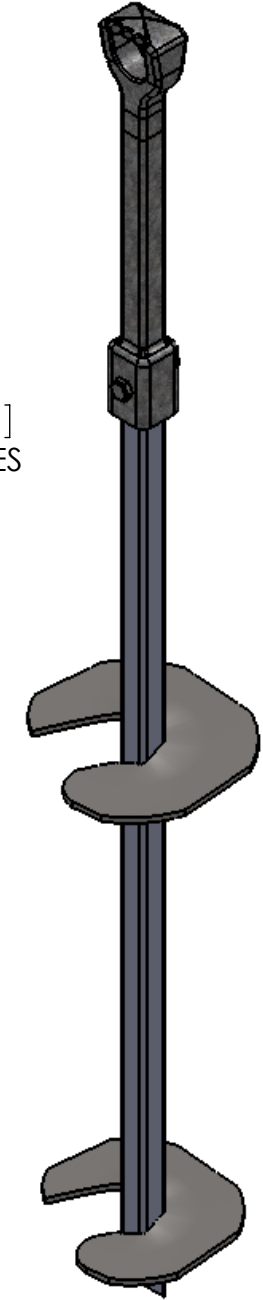

This drawing contains confidential information that is the property of MacLean Power, L.L.C. ("MacLean"). Use of MacLean's confidential information without MacLean's express written consent is strictly prohibited and may expose you to legal liability. If you believe that you received this material in error, please destroy it or return it to "MacLean Power, L.L.C., 11411 Addison Street, Franklin Park, Illinois 60131, "USA."

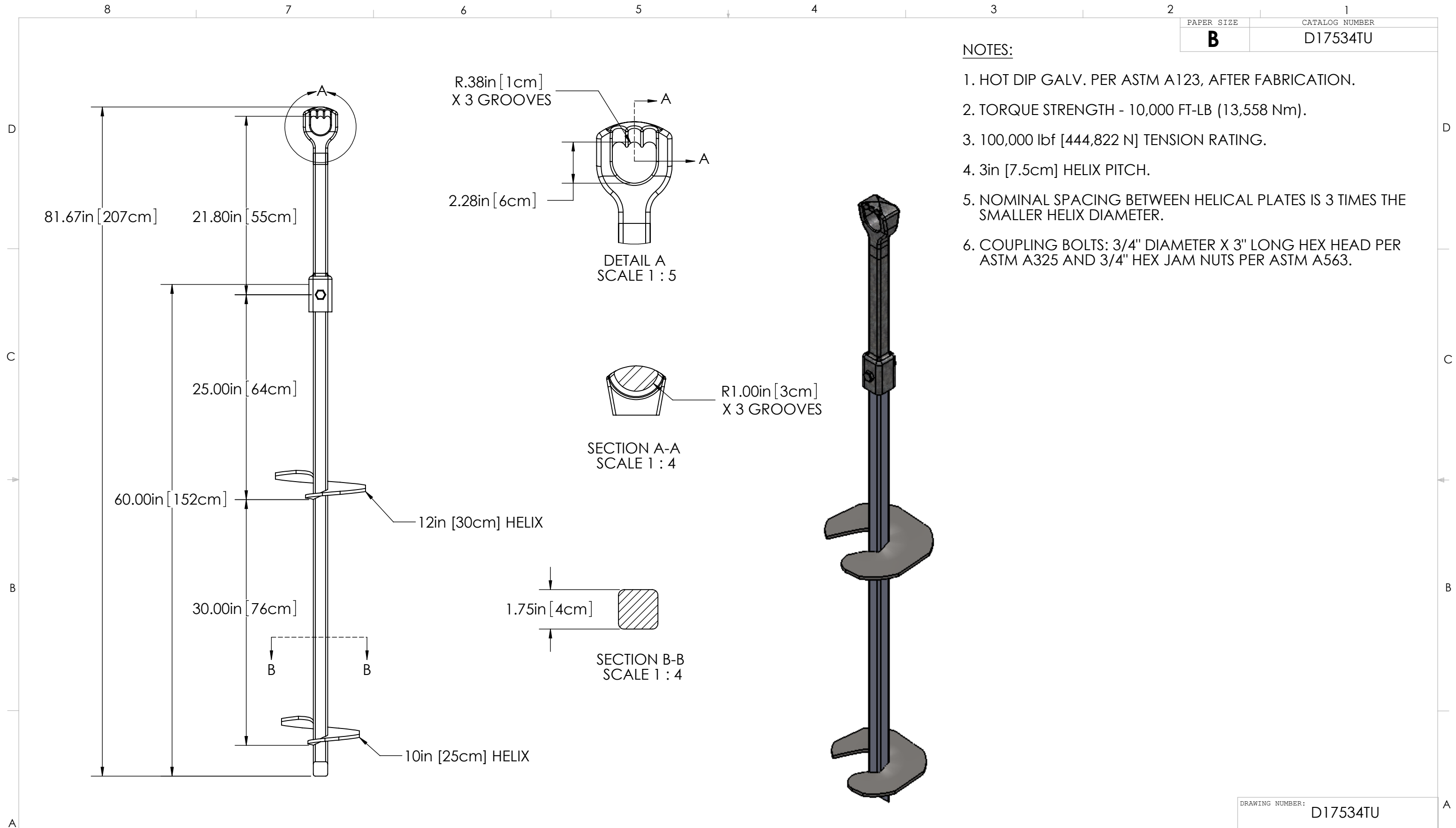

DRAWING NUMBER: D17534TU	
SHEET NAME: SHEET1	1 OF 1
PRODUCT DESCRIPTION 1-3/4" 10,000 ft/lb POWER SHAFT SQUARE SHAFT LEAD	
DRAWN BY: CRL	DATE: 3/15/12