

1

2

3

4

5

COMPONENT SPECIFICATION

USE OR REPRODUCTION OF THIS DRAWING FOR THE PURPOSE OF MANUFACTURING THIS ARTICLE OR ANY ARTICLES SHOWN FOR ANY PURPOSE IS STRICTLY PROHIBITED WITHOUT WRITTEN PERMISSION FROM SENIOR INDUSTRIES, INC.

SPECIFICATIONS

MATERIAL

CONNECTOR BODY: COPPER ALLOY  
STUD: STAINLESS STEEL  
SET SCREW: STAINLESS STEEL

MECHANICAL

RANGE: MINIMUM WIRE PAIR #8 SOL TO #5 SOL COPPER WIRE  
MAXIMUM WIRE PAIR 1/0 STR TO #4 SOL COPPER WIRE  
SET SCREW/STUD WIRE RANGE #14 TO #6 SOL COPPER WIRE

AGENCY APPROVALS: UL FILE NO. E147880

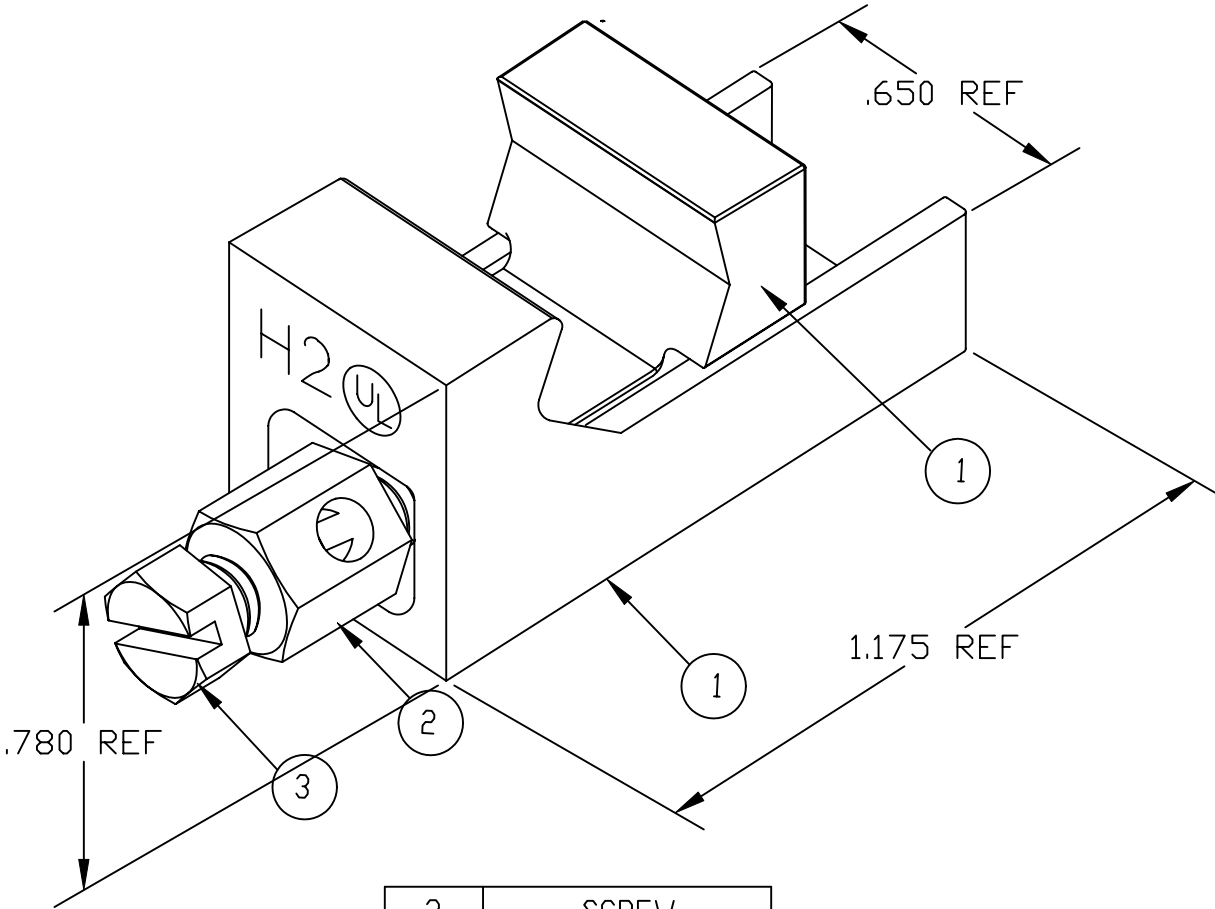

3	SCREW
2	STUD
1	CONNECTOR BODY
ITEM	DESCRIPTION



SENIOR INDUSTRIES, INC.

DESIGNED:			SYM.	DATE:	DESCRIPTION OF REVISIONS:	DRAWN:	APPD:	TOLERANCE:	PART NO:	SI-0082JK
DRAWN:	MAW	06/01/11	▲	06.01.11	NEW	MAW	JF	TO 1 DECIMAL PLACE: ±	TITLE:	CLAMP ASSEMBLY
CHECKED:	MAW	06/01/11	▲	06.01.11	Added UL file number	MAW	JF			
APPROVED:	JF	06/01/11	▲	..				AS ANGLES: ±	SHEET:	1 OF 1
3RD ANGLE		UNIT:	IN	SCALE:	2:1	REV:	B			