

1

2

3

4

COMPONENT SPECIFICATION

USE OR REPRODUCTION OF THIS DRAWING FOR THE PURPOSE OF MANUFACTURING THIS ARTICLE OR ANY ARTICLES SHOWN FOR ANY PURPOSE IS STRICTLY PROHIBITED WITHOUT WRITTEN PERMISSION FROM SENIOR INDUSTRIES, INC.

A

B

C

D

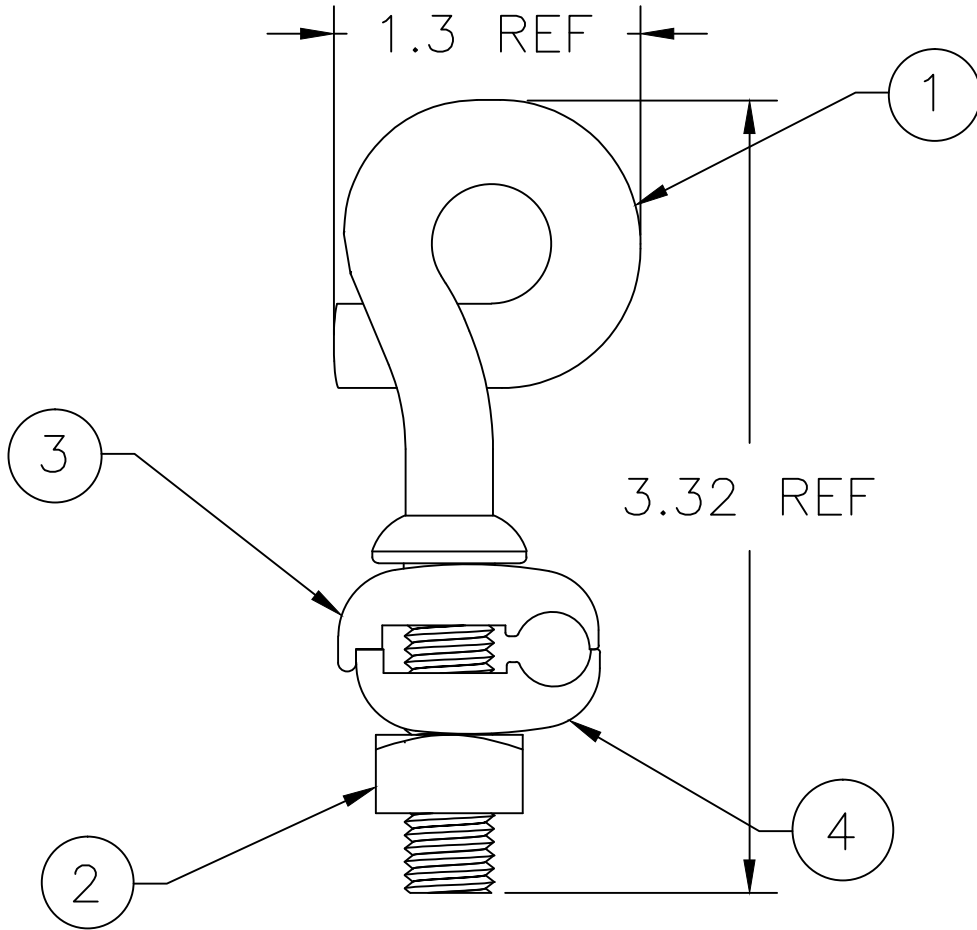

4	LOWER PLATE	ALUMINUM
3	UPPER PLATE	ALUMINUM
2	SQUARE NUT	STEEL, MECHANICALLY PLATED
1	□ BOLT	STEEL, MECHANICALLY PLATED
ITEM	DESCRIPTION	MATERIAL

DESIGNED:

SYM.

DATE:

DESCRIPTION OF REVISIONS:

DRAWN

APPD.

DRAWN:

HV

05/25/01

▲

05.25.01

NEW

RB

CHECKED:

▲

. .

APPROVED:

▲

. .

▲

. .

3RD ANGLE

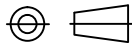

UNIT:

inches

SCALE:

REV.

A



SENIOR INDUSTRIES, INC.

TOLERANCE:

TO 1 DECIMAL PLACE: ±

TO 2 DECIMAL PLACES: ±

AS ANGLES: ± °

SHEET:

PART NO:

SI-0514

TITLE:

0 SPAN CLAMP

1 OF 1

E