

COMPONENT SPECIFICATION

USE OR REPRODUCTION OF THIS DRAWING FOR THE PURPOSE OF MANUFACTURING THIS ARTICLE OR ANY ARTICLES SHOWN FOR ANY PURPOSE IS STRICTLY PROHIBITED WITHOUT WRITTEN PERMISSION FROM MACLEAN SENIOR INDUSTRIES, LLC

A
B
C

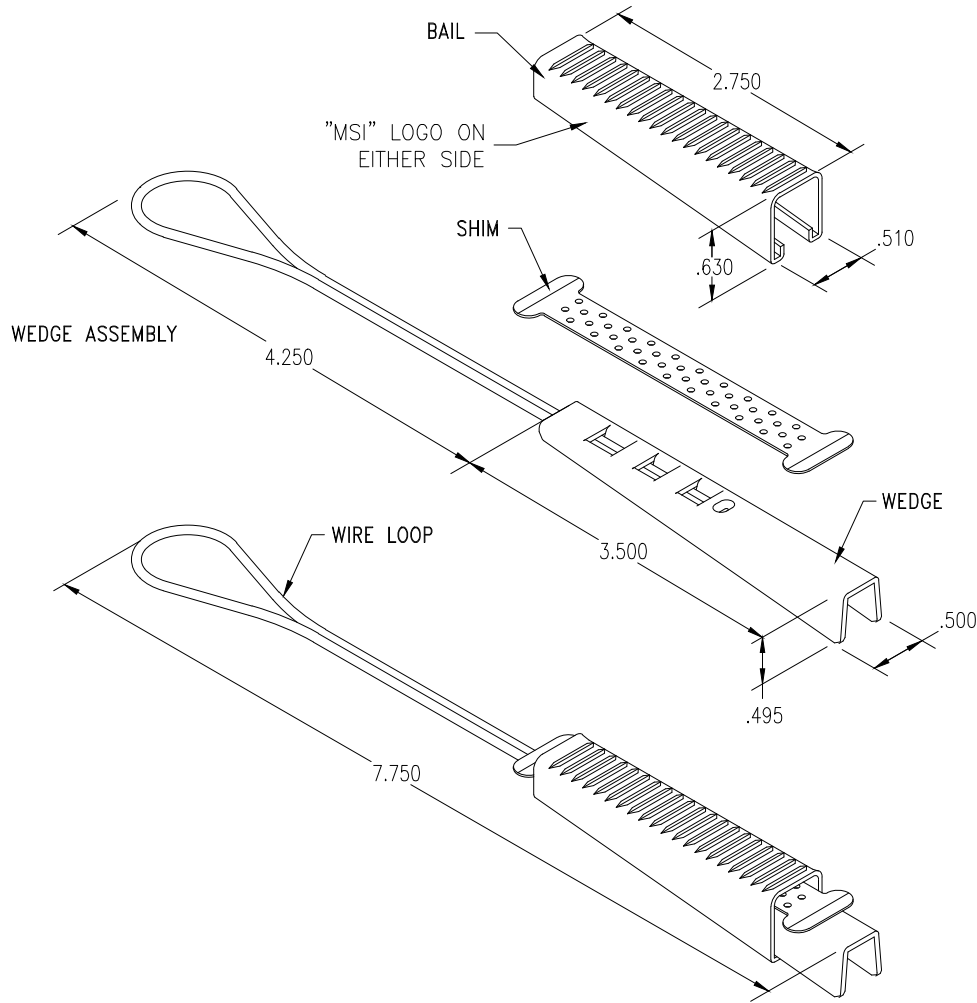

SPECIFICATIONS:

MECHANICAL:

RANGE: USED WITH 2 PAIR DROP WIRES
 TEST LOAD: WIRE CRIMPED TO WEDGE SHALL WITHSTAND 555 LBS OF SEPARATION FORCE WITHOUT BREAKING OR PULLING OUT.

MATERIAL:

BAIL, SHIM AND WEDGE: ALUMINUM ALLOY
 WIRE LOOP: .081 ϕ , STAINLESS STEEL 430



DESIGNED:			SYM.	DATE:	DESCRIPTION OF REVISIONS:	DRAWN:	APPD:	TOLERANCE:	PART NO:	SI-0959	
DRAWN:	GAT	05/16/08	Δ	05.16.08	NEW	GAT	JF				
CHECKED:	GAT	05/16/08	Δ	.	.			TO 2 DECIMAL PLACES: \pm	TITLE:	DROP WIRE CLAMP	
APPROVED:	JF	05/16/08	Δ	.	.			TO 3 DECIMAL PLACES: \pm			
3RD ANGLE		UNIT:	inches	SCALE:		REV.	A	AS ANGLES:	\pm	SHEET:	1 OF 1