

1	2	3	4	5
COMPONENT SPECIFICATION	USE OR REPRODUCTION OF THIS DRAWING FOR THE PURPOSE OF MANUFACTURING THIS ARTICLE OR ANY ARTICLES SHOWN FOR ANY PURPOSE IS STRICTLY PROHIBITED WITHOUT WRITTEN PERMISSION FROM SENIOR INDUSTRIES, INC.			

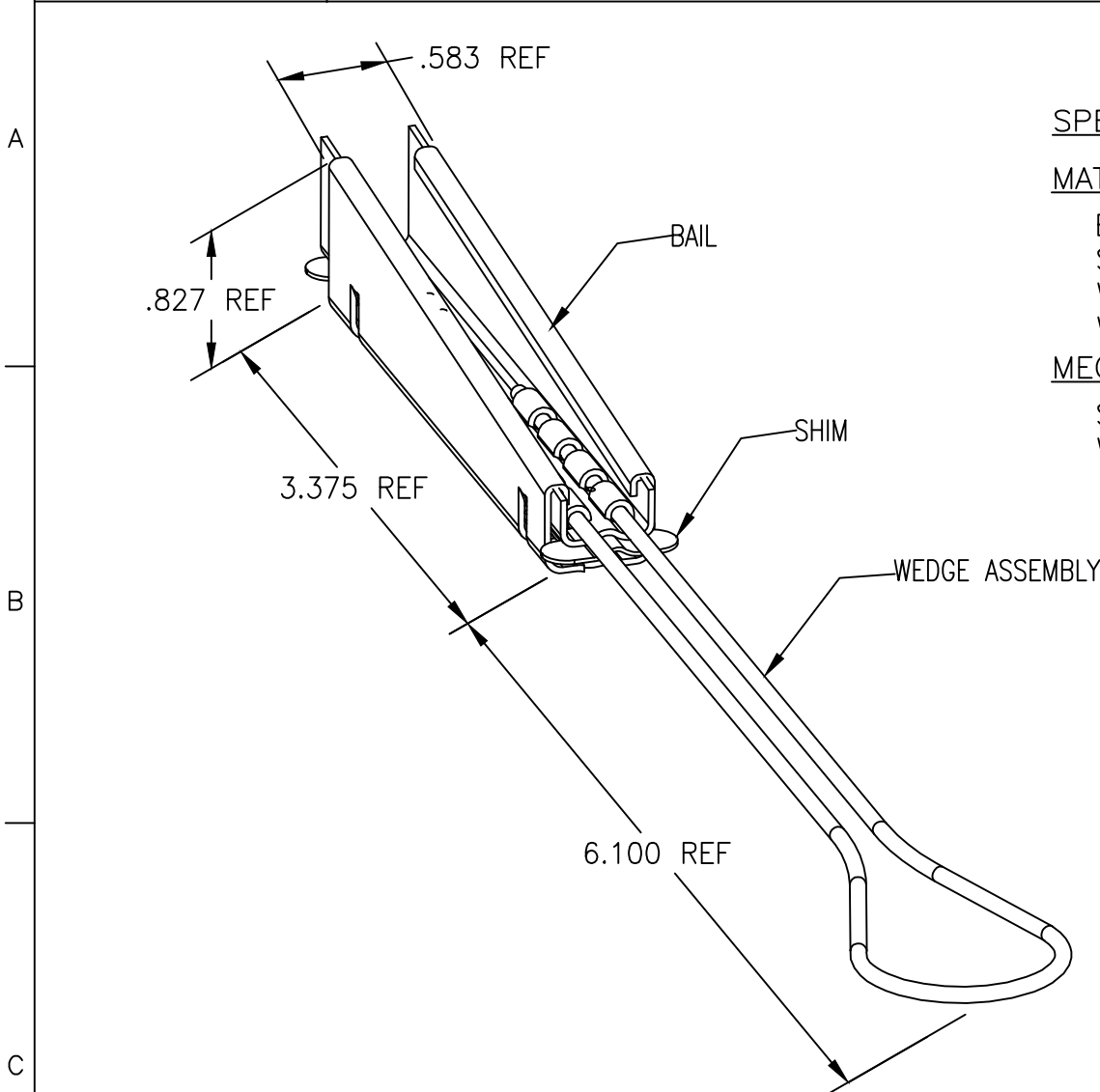

SPECIFICATIONS

MATERIALS

BAIL: 300 SERIES STAINLESS STEEL
 SHIM: 300 SERIES STAINLESS STEEL
 WEDGE BODY: 300 SERIES STAINLESS STEEL
 WIRE LOOP: 430 STAINLESS STEEL

MECHANICAL

SHALL WITHSTAND 200 POUNDS PULL FORCE WHEN USING SUMITOMO FIBER OPTIC CABLE.

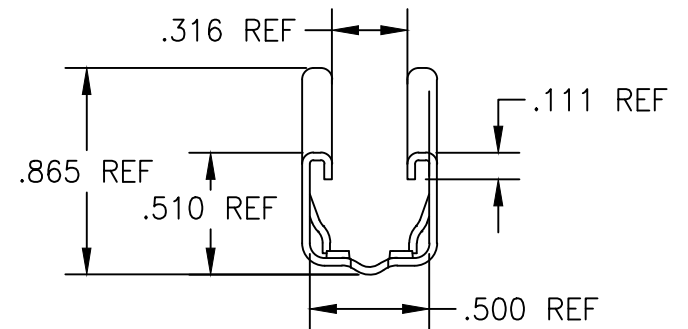

SENIOR INDUSTRIES, INC.

DESIGNED:			SYM.	DATE:	DESCRIPTION OF REVISIONS:	DRAWN:	APPD:	TOLERANCE:	PART NO:	SI-0972
DRAWN:	MAW	03/25/11	▲	03.25.11	NEW	MAW	JF			
CHECKED:	MAW	03/25/11	▲	06.20.12	Added mechanical force specification			TO 3 DECIMAL PLACES: ±	SHEET:	1 OF 1
APPROVED:	JF	03/25/11	▲					AS ANGLES: ±		
3RD ANGLE			UNIT:	IN	SCALE:	N/A	REV:	B		