

1

2

3

4

5

COMPONENT SPECIFICATION

USE OR REPRODUCTION OF THIS DRAWING FOR THE PURPOSE OF MANUFACTURING THIS ARTICLE OR ANY ARTICLES SHOWN FOR ANY PURPOSE IS STRICTLY PROHIBITED WITHOUT WRITTEN PERMISSION FROM SENIOR INDUSTRIES, INC.

SPECIFICATIONS

MATERIAL

CONNECTOR BODY: HIGH STRENGTH BRONZE ALLOY
STUD: STEEL

MECHANICAL

RANGE: 5/16" OR 1/4" GALVANIZED STEEL STRAND WITH NO. 6 AWG SOLID COPPER.

REGULATORY

COMPLIES WITH UL STANDARD 467 FOR GROUNDING AND BONDING EQUIPMENT. UL/CUL APPROVAL FILE E137532.

A

B

C

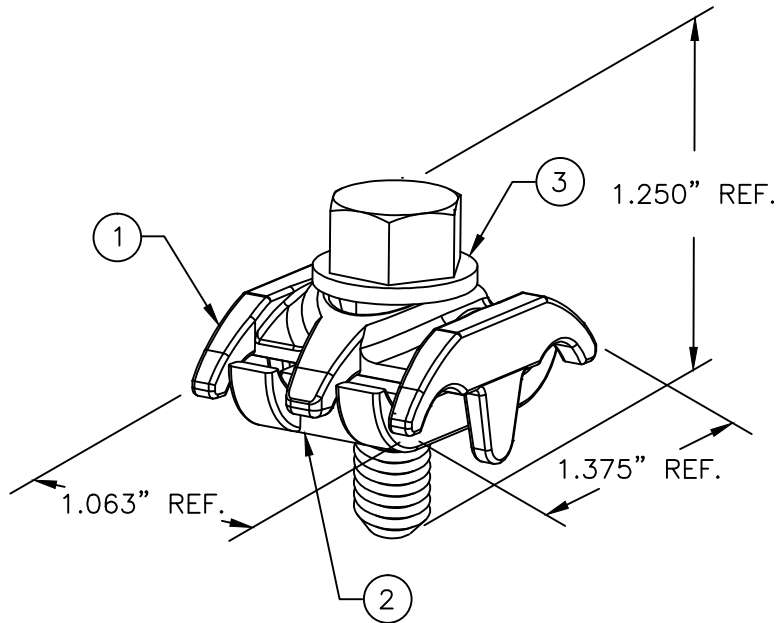

3	5/16-18 STUD
2	LOWER JAW
1	UPPER JAW
ITEM	DESCRIPTION



SENIOR INDUSTRIES, INC.

DESIGNED:			SYM.	DATE:	DESCRIPTION OF REVISIONS:	DRAWN:	APPD:	TOLERANCE:	PART NO:	SI-2174
DRAWN:	MAW	03/21/11	▲	03.21.11	NEW	MAW	JF	TO 2 DECIMAL PLACE: ±	TITLE:	BONDING CLAMP
CHECKED:	MAW	03/21/11	▲	03.29.12	Correct stud material	MAW	JF			
APPROVED:	JF	03/21/11	▲	.	.			AS ANGLES: ±	SHEET:	1 OF 1
3RD ANGLE		UNIT:	inches	SCALE:	N/A	REV.	A			