

COMPONENT SPECIFICATION

USE OR REPRODUCTION OF THIS DRAWING FOR THE PURPOSE OF MANUFACTURING THIS ARTICLE OR ANY ARTICLES SHOWN FOR ANY PURPOSE IS STRICTLY PROHIBITED WITHOUT WRITTEN PERMISSION FROM SENIOR INDUSTRIES, INC.

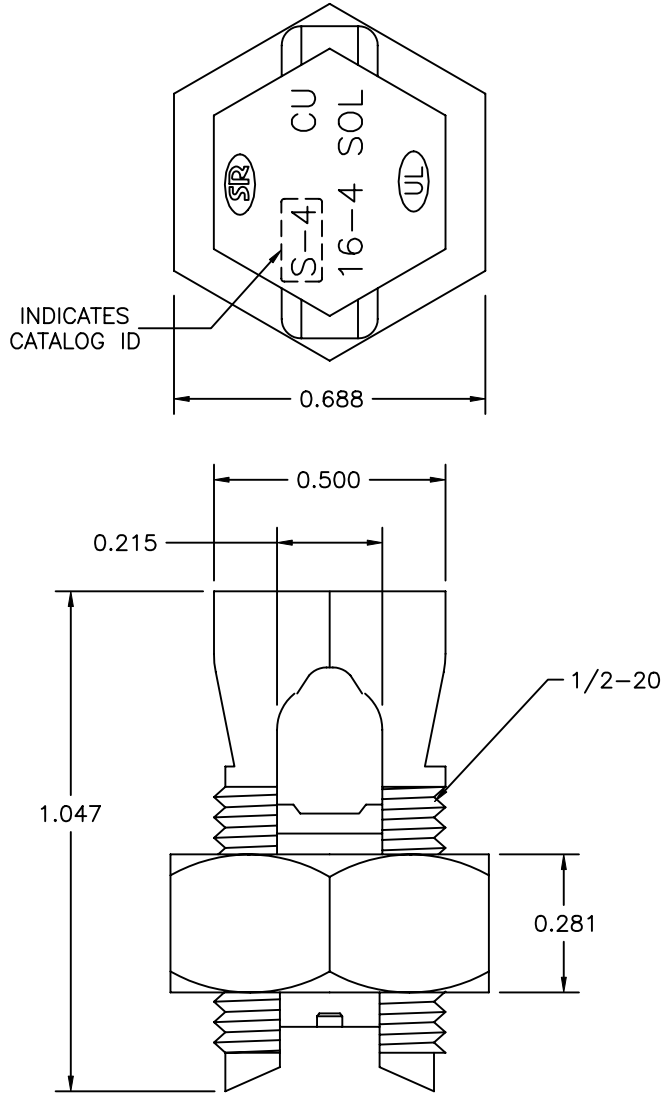

SPECIFICATIONS:

RANGE: TWO #6 SOLID COPPER AWG
 TORQUE: 165 IN-LBS MINIMUM
 AGENCY APPROVALS: UL/CUL FILE NO. E197571

MATERIAL:
 BOLT: HIGH STRENGTH COPPER ALLOY
 SPACER: COPPER
 NUT: HIGH STRENGTH COPPER ALLOY



SENIOR INDUSTRIES, INC.

DESIGNED:			SYM.	DATE:	DESCRIPTION OF REVISIONS:	DRAWN:	APPD:	TOLERANCE:	PART NO:	SI-2004
DRAWN:	HV	06/11/01	▲	04.23.07	NEW	GAT	JF			
CHECKED:	GAT	04/23/07	▲	.	.			TO 2 DECIMAL PLACE: ±	TITLE	SPLIT BOLT
APPROVED:	JF	04/23/07	▲	.	.			TO 3 DECIMAL PLACES: ±	SHEET:	1 OF 1
3RD ANGLE		UNIT:	IN	SCALE:	3:1	REV.	A	AS ANGLES: ±		