

1

2

3

4

5

COMPONENT SPECIFICATION

USE OR REPRODUCTION OF THIS DRAWING FOR THE PURPOSE OF MANUFACTURING THIS ARTICLE OR ANY ARTICLES SHOWN FOR ANY PURPOSE IS STRICTLY PROHIBITED WITHOUT WRITTEN PERMISSION FROM SENIOR INDUSTRIES, INC.

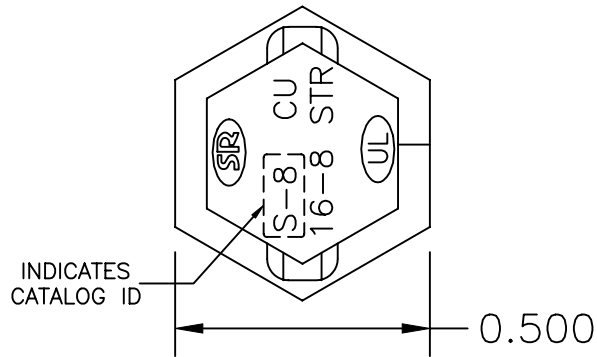

SPECIFICATIONS:

RANGE: #8 STRANDED COPPER AWG  
 TORQUE: 80 IN-LBS MINIMUM  
 AGENCY APPROVALS: UL/CUL FILE NO. E197571

MATERIAL:  
 BOLT: HIGH STRENGTH COPPER ALLOY  
 SPACER: COPPER  
 NUT: HIGH STRENGTH COPPER ALLOY

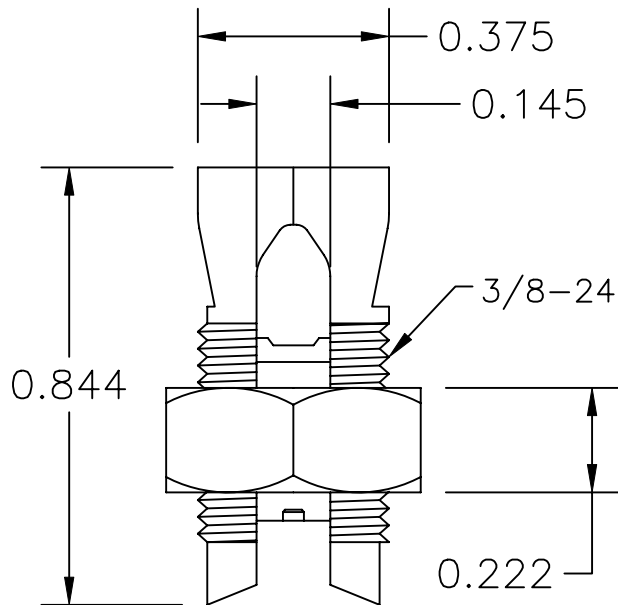

**SENIOR INDUSTRIES, INC.**

DESIGNED:			SYM.	DATE:	DESCRIPTION OF REVISIONS:	DRAWN:	APPD:	TOLERANCE:	PART NO:	SI-2008
DRAWN:	HV	06/11/01	▲	04.19.07	NEW	GAT	JF			
CHECKED:	GAT	04/19/07	▲	. .				TO 2 DECIMAL PLACE: ±	TITLE	SPLIT BOLT
APPROVED:	JF	04/19/07	▲	. .				TO 3 DECIMAL PLACES: ±	SHEET:	1 OF 1
3RD ANGLE			UNIT:	IN	SCALE:	3:1	REV.	A	AS ANGLES:	±