

1

2

3

4

5

COMPONENT SPECIFICATION

USE OR REPRODUCTION OF THIS DRAWING FOR THE PURPOSE OF MANUFACTURING THIS ARTICLE OR ANY ARTICLES SHOWN FOR ANY PURPOSE IS STRICTLY PROHIBITED WITHOUT WRITTEN PERMISSION FROM SENIOR INDUSTRIES, INC.

SPECIFICATIONS:

MECHANICAL:

RANGE: #12-#10 COPPER GROUND WIRE
INSTALLATION TORQUE: APPROX. 35 IN-LBS MIN.
AGENCY APPROVALS: UL/CUL FILE NO. E137532

MATERIAL:

BRACKET: .048" THICK STAINLESS STEEL - HARD TEMPER
STUD: 300 SERIES STAINLESS STEEL
SCREW: 300 SERIES STAINLESS STEEL
CONTACT PLATE: .045" THICK 300 SERIES STAINLESS STEEL

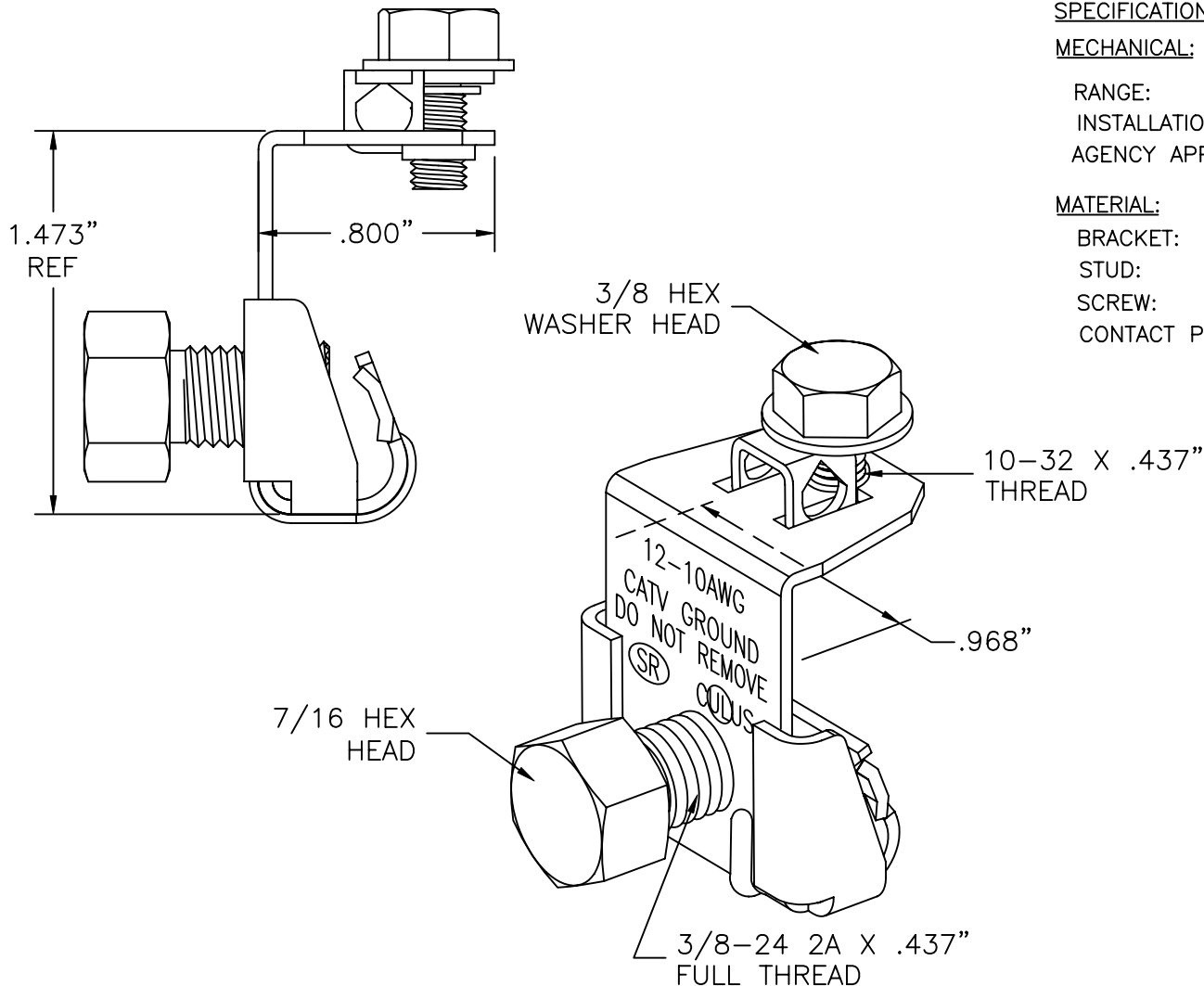

DESIGNED:			SYM.	DATE:	DESCRIPTION OF REVISIONS:	DRAWN:	APPD:
DRAWN:	RB	09/04/02	△	05.02.07	NEW	GAT	JF
CHECKED:	GAT	05/02/07	△	.	.		
APPROVED:	JF	05/02/07	△	.	.		

TOLERANCE:	PART NO:	SI-2167GC
TO 2 DECIMAL PLACE: ±	TITLE:	GROUND BRACKET ASSY.
TO 3 DECIMAL PLACES: ±	SHEET:	1 OF 1

3RD ANGLE	UNIT:	IN	SCALE:	2:1	REV:	A
-----------	-------	----	--------	-----	------	---