

1

2

3

4

5

COMPONENT SPECIFICATION

USE OR REPRODUCTION OF THIS DRAWING FOR THE PURPOSE OF MANUFACTURING THIS ARTICLE OR ANY ARTICLES SHOWN FOR ANY PURPOSE IS STRICTLY PROHIBITED WITHOUT WRITTEN PERMISSION FROM SENIOR INDUSTRIES, INC.

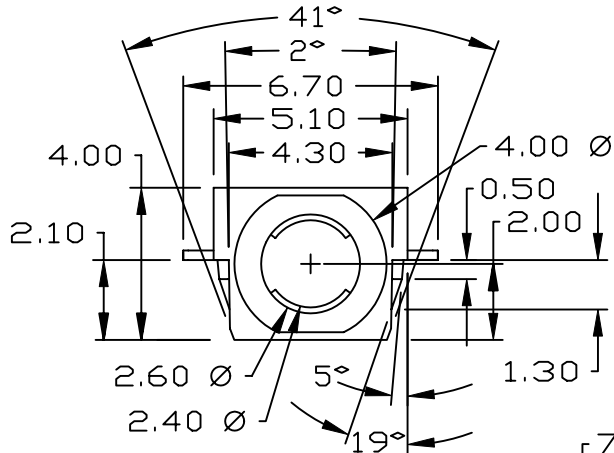

6	BACK COVER	NYLON FR52, BLACK
5	DUMMY SPRING	.20mm BeCu ALLOY, GOLD OVER Ni
4	RING SPRING	.20mm BeCu ALLOY, GOLD OVER Ni
3	SLEEVE SPRING	.25mm BeCu ALLOY, GOLD OVER Ni
2	TIP SPRING	.20mm BeCu ALLOY, GOLD OVER Ni
1	HOUSING	NYLON FR52, BLACK
ITEM	DESCRIPTION	MATERIAL/FINISH

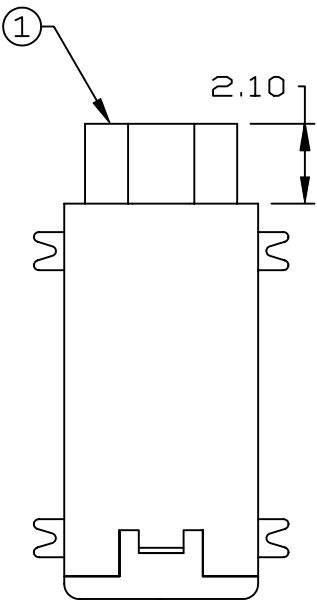
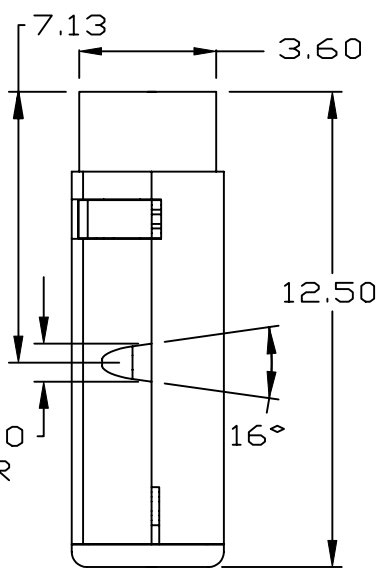
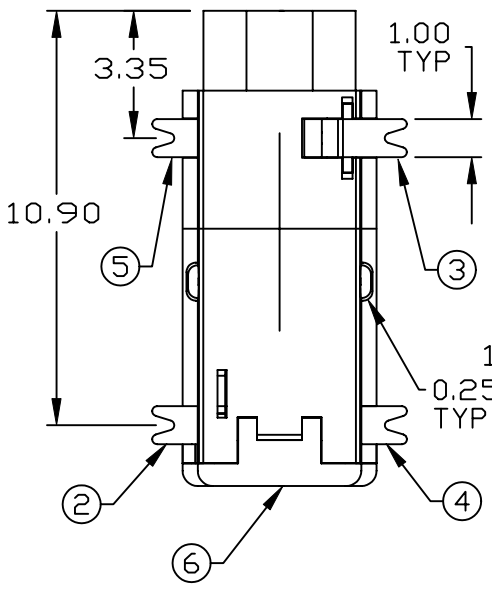
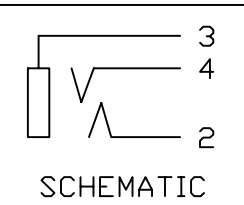
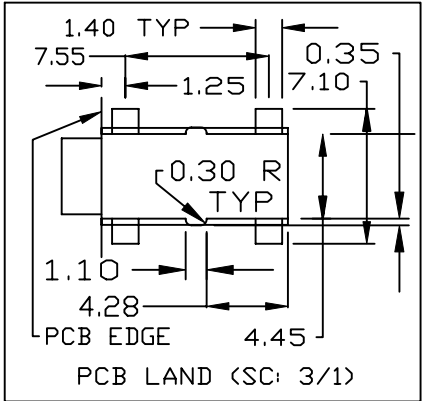

**SENIOR INDUSTRIES, INC.**

DESIGNED:			SYM.	DATE:	DESCRIPTION OF REVISIONS:	DRAWN:	APPD:
DRAWN:	HV	02/10/01	▲	03.10.01	NEW	RB	JF
CHECKED:	TF	05/23/01	▲	03.27.01	Added pin/markings	RB	JF
APPROVED:	JF	05/23/01	▲	04.18.01	Corr bottom view showing term # & locations	RB	JF
			▲	05.23.01	Added back cover.	RB	JF

TOLERANCE:  
TO 1 DECIMAL PLACE: ±.3  
TO 2 DECIMAL PLACES: ±.12  
AS ANGLES: ±1/2°

PART NO:	SI-583
TITLE:	AUDIO JACK
SHEET:	1 OF 2

3RD ANGLE UNIT: mm SCALE: 6:1 REV: D

1

2

3

4

5

COMPONENT  
SPECIFICATION

USE OR REPRODUCTION OF THIS DRAWING FOR THE PURPOSE OF MANUFACTURING THIS ARTICLE OR ANY ARTICLES SHOWN FOR ANY PURPOSE IS STRICTLY PROHIBITED WITHOUT WRITTEN PERMISSION FROM SENIOR INDUSTRIES, INC.

SPECIFICATIONS:ELECTRICAL:

CONTACT RATING: 1A @ 12 VDC  
 CONTACT RESISTANCE: 30 MILLIOHMS MAX.  
 INSULATION RESISTANCE: 100 MEGOHMS MIN. @ 500 VDC  
 DIELECTRIC STRENGTH: 500 VRMS FOR 1 MINUTE

MECHANICAL:

INSERTION FORCE: 300-2,000 GRAMS  
 WITHDRAWAL FORCE: 300-2,000 GRAMS  
 OPERATING LIFE: 6,000 CYCLES  
 CONTACT RETENTION FORCE: 80 GRAMS  
 CONTACT PLATING: 30 MICRONS GOLD OVER  
 50 MICRONS NICKEL  
 SOLDERABILITY: 95% WETTING MIN. AFTER 15  
 SECONDS DIP IN 230°C SOLDER

ENVIRONMENTAL:

STORAGE TEMPERATURE RANGE: -40°C TO +100°C  
 OPERATING TEMPERATURE RANGE: -40°C TO +85°C  
 PART SHALL WITHSTAND REFLOW SOLDER TEMPERATURE OF  
 230°C FOR 15 SECONDS.

TAPE REEL PACKAGING:

WIDTH: 24mm  
 PITCH: 12mm  
 REEL DIAMETER: 382mm  
 ORIENTATION: JACK OPENING FACING SIDE WITH SPROCKET HOLES



**SENIOR  
INDUSTRIES, INC.**

DESIGNED:			SYM.	DATE:	DESCRIPTION OF REVISIONS:	DRAWN:	APPD:	TOLERANCE:	PART NO:	SI-583
DRAWN:	HV	02/10/01	▲	03.10.01	NEW	RB	JF			
CHECKED:	TF	05/23/01	▲	03.27.01	Added pin/markings	RB	JF			
APPROVED:	JF	05/23/01	▲	04.18.01	Corr bottom view showing term # & locations	RB	JF	AS ANGLES: ±1/2'	SHEET:	2 OF 2
			▲	05.23.01	Added back cover.	RB	JF			
<b>3RD ANGLE</b>			UNIT:	mm	SCALE:	6:1	REV:	D		

A

B

C