

COMPONENT SPECIFICATION

USE OR REPRODUCTION OF THIS DRAWING FOR THE PURPOSE OF MANUFACTURING THIS ARTICLE OR ANY ARTICLES SHOWN FOR ANY PURPOSE IS STRICTLY PROHIBITED WITHOUT WRITTEN PERMISSION FROM SENIOR INDUSTRIES, INC.

SPECIFICATIONS

ELECTRICAL

CONTACT RATING: 24 VDC @ 3.5 Amps DC
 CONTACT RESISTANCE:
 PLUG TO CONTACTS: 50 MILLIOHMS MAX.
 CONTACT TO SHUNT: 30 MILLIOHMS MAX.
 INSULATION RESISTANCE: 100 MEGOHMS MIN. @ 500 VDC
 DIELECTRIC STRENGTH: 500 VAC FOR 1 MINUTE

MECHANICAL

LIFE: 5000 CYCLES
 INSERTION FORCE: 0.3 Kg TO 2.0 Kg
 WITHDRAWAL FORCE: 0.3 Kg TO 2.0 Kg

ENVIRONMENTAL

STORAGE TEMPERATURE: -40°C TO +100°C
 OPERATING TEMPERATURE: -25°C TO +85°C
 HUMIDITY RANGE: 10% RH TO 80% RH
 PART SHALL WITHSTAND REFLOW SOLDER TEMPERATURE OF 240°C FOR 10 SECONDS.

MATERIAL

HOUSING: POLYAMIDE, UL94V-0, BLACK
 COVER: POLYAMIDE, UL94V-0, BLACK
 SLEEVE SHUNT: BRASS, SILVER PLATED, .40t
 SLEEVE SPRING: PHOSPHOR BRONZE, SILVER PLATED, .30t
 PIN TERMINAL: BRASS, SILVER PLATED, .30t
 PIN (ø2.0/2.5mm): COPPER ALLOY, NICKEL PLATED

PACKAGING

TAPE WIDTH: 44mm
 TAPE PITCH: 23mm
 REEL SIZE: 380mm

1st 'X' = PIN ø	DIA.	TOLER.
A	2.00	±0.05
B	2.45	±0.05

PART NO.	2nd 'X' = PACKAGING:
SI-674-A	TAPE & REEL (250 PCS/REEL)
SI-674-A-1	BULK
SI-674-B	TAPE & REEL (250 PCS/REEL)
SI-674-B-1	BULK

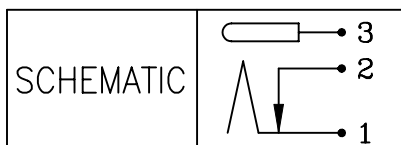
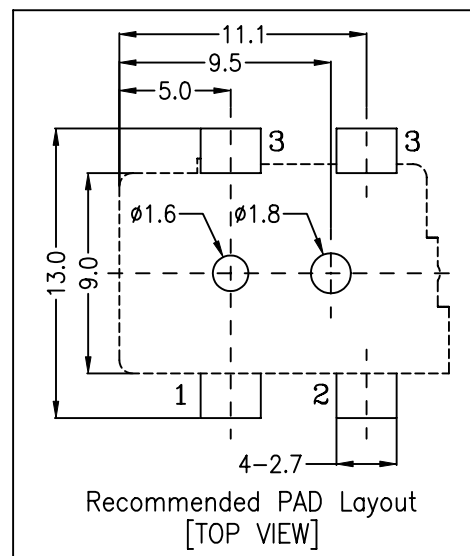
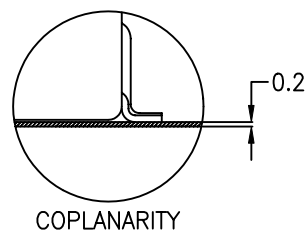
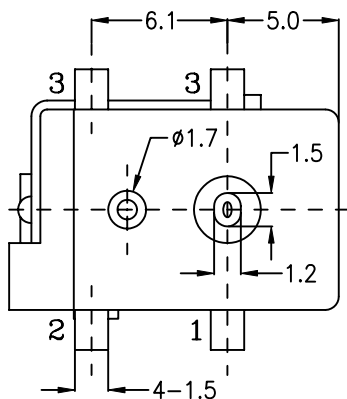
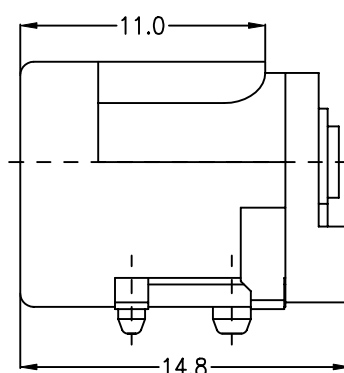
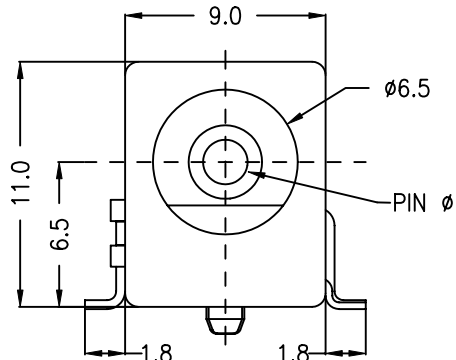
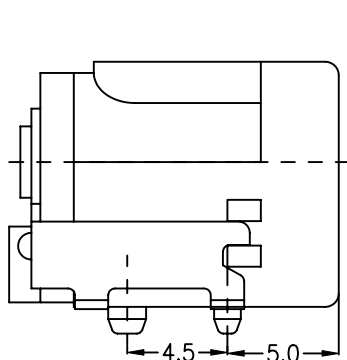

DESIGNED:			SYM.	DATE:	DESCRIPTION OF REVISIONS:	DRAWN:	APPD:
DRAWN:	GAT	12/15/04	▲	04.22.05	NEW	GAT	JF
CHECKED:	GAT	09/15/05	▲	09.15.05	Corr '-1' option from 'Tray' pack. to 'Bulk' pack.	GAT	JF
APPROVED:	JF	09/16/05	▲				
3RD ANGLE		UNIT:	mm	SCALE:	4:1	REV:	B

TOLERANCE:	PART NO:	SI-674-X-X
TO 1 DECIMAL PLACE: ±.2	TITLE:	SMT ø2.0/ø2.5mm DC POWER JACK
TO 2 DECIMAL PLACES: ±.10	SHEET:	1 OF 1
AS ANGLES: ±1/2°		