

1

2

3

4

5

COMPONENT SPECIFICATION

USE OR REPRODUCTION OF THIS DRAWING FOR THE PURPOSE OF MANUFACTURING THIS ARTICLE OR ANY ARTICLES SHOWN FOR ANY PURPOSE IS STRICTLY PROHIBITED WITHOUT WRITTEN PERMISSION FROM SENIOR INDUSTRIES, INC.

SPECIFICATIONS

ELECTRICAL

CONTACT RATING: 250mA @ 130 VAC
CONTACT RESISTANCE: 20 MILLIOHMS MAX.
INSULATION RESISTANCE: 10,000 MEGOHMS MIN. @ 500 VDC
DIELECTRIC STRENGTH: 500 VAC FOR 1 MINUTE

MECHANICAL

LIFE: 10,000 CYCLES
INSERTION FORCE: 7.0 Lbs MAX.
WITHDRAWAL FORCE: 1.5 Lbs MIN.

ENVIRONMENTAL

OPERATING TEMPERATURE: -40°C TO +85°C

REGULATORY:

UL RECOGNIZED COMPONENT. UL FILE NO. E147880.

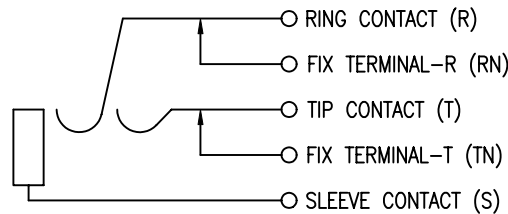
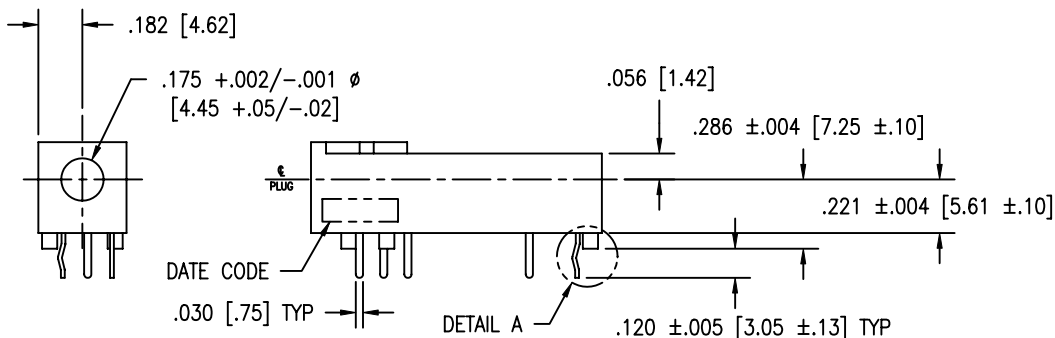

NOTE: 'X' IN PART NUMBER DENOTES HOUSING COLOR:

- 1 - BLUE, 2 - RED, 3 - BLACK (STD), 4 - BROWN, 5 - GREEN, 6 - WHITE, 7 - GRAY, 8 - ORANGE, 9 - YELLOW, 10 - VIOLET, 11 - IVORY/NEUTRAL

SCHEMATIC

Table with 3 columns: PART, QTY, MATERIAL/FINISH. Rows include BODY, TIP CONTACT (T), RING CONTACT (R), FIX TERMINAL-T (TN), FIX TERMINAL-R (RN), and SLEEVE CONTACT (S).

RoHS COMPLIANT



SENIOR INDUSTRIES, INC.

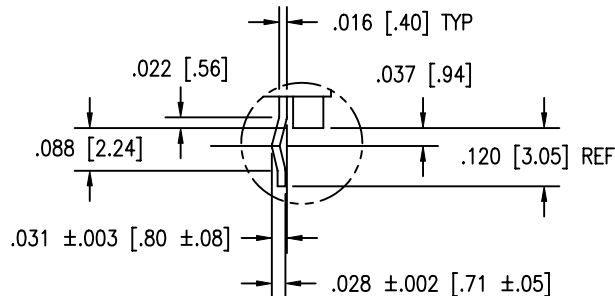
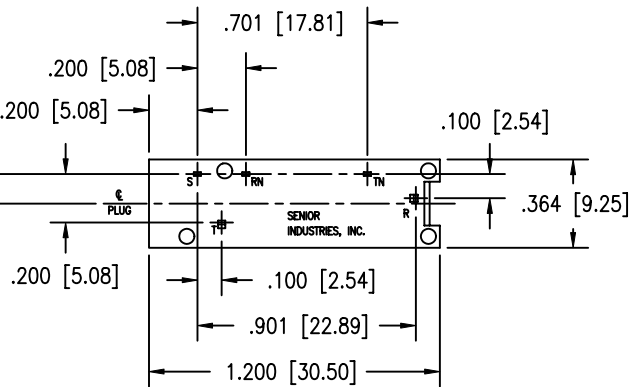

DETAIL A SCALE 4/1

Table with columns: DESIGNED, DRAWN, CHECKED, APPROVED, SYM, DATE, DESCRIPTION OF REVISIONS, DRAWN, APPD.

Table with columns: TOLERANCE, PART NO, TITLE, SHEET.