

1	2	3	4	5
COMPONENT SPECIFICATION	USE OR REPRODUCTION OF THIS DRAWING FOR THE PURPOSE OF MANUFACTURING THIS ARTICLE OR ANY ARTICLES SHOWN FOR ANY PURPOSE IS STRICTLY PROHIBITED WITHOUT WRITTEN PERMISSION FROM SENIOR INDUSTRIES, INC.			

HEX SHOULDER THIS SIDE

3/8-32 X 1/2 X 0.100 STAINLESS STEEL HEX NUT

SI-SG-81  
2.2 GHz, 360° CONTACT  
F CONNECTOR W/O RINGS

3/8 STAINLESS STEEL INTERNAL TOOTH LOCK WASHER WITH TEETH ORIENTED TOWARDS BRACKET

.818

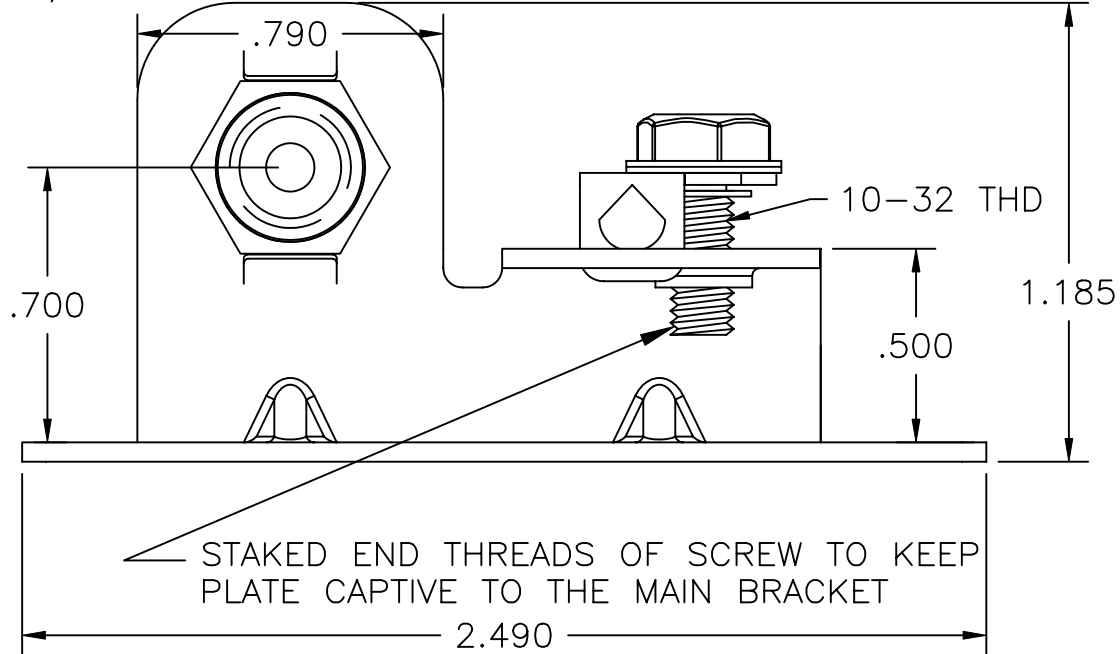

10-32 THD

**NOTES:**

1. GROUNDING CLIP SHALL ACCEPT #6 GROUND WIRE.
2. F CONNECTOR TORQUE TO INSTALL 55 IN-LBS, TORQUE TO REMOVE, TARGET 40-48 IN-LBS, 35 IN-LBS MIN.
3. GROUND BLOCK ASSY TO BE PACKED IN A PLASTIC BAG.

**MATERIAL:**

BRACKET: .050" THICK STAINLESS STEEL, SAND BLAST FINISH  
 10-32 X .437" SCREW: STAINLESS STEEL  
 CONTACT PLATE: .045" THICK STAINLESS STEEL



DESIGNED:			SYM.	DATE:	DESCRIPTION OF REVISIONS:	DRAWN:	APPD:	TOLERANCE:	PART NO:	SI-GB-50		
DRAWN:	GAT	03/16/07	▲	12.06.07	NEW	GAT	JF				TO 2 DECIMAL PLACE: ± TO 3 DECIMAL PLACES: ± AS ANGLES: ±	TITLE:
CHECKED:	GAT	12/06/07	▲	.	.			SHEET:	1 OF 1			
APPROVED:	JF	12/06/07	▲	.	.							
<b>3RD ANGLE</b>		UNIT:	IN	SCALE:	2:1	REV:	A					