

COMPONENT SPECIFICATION

USE OR REPRODUCTION OF THIS DRAWING FOR THE PURPOSE OF MANUFACTURING THIS ARTICLE OR ANY ARTICLES SHOWN FOR ANY PURPOSE IS STRICTLY PROHIBITED WITHOUT WRITTEN PERMISSION FROM SENIOR INDUSTRIES, INC.

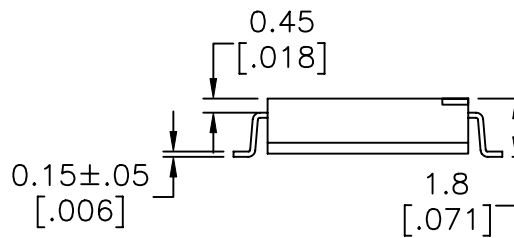

SRHS106L SHOWN

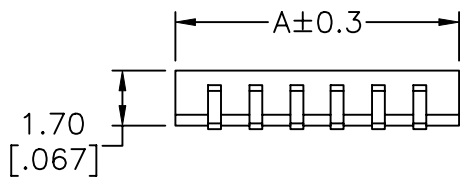
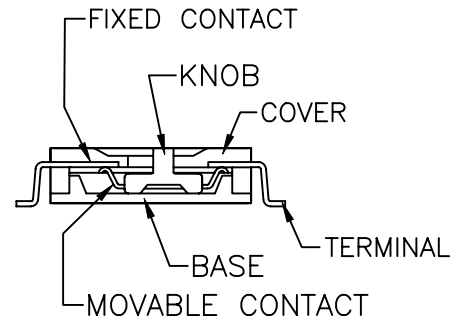
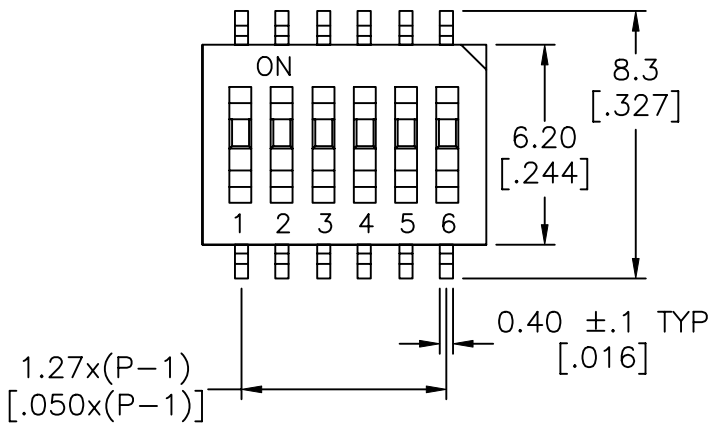
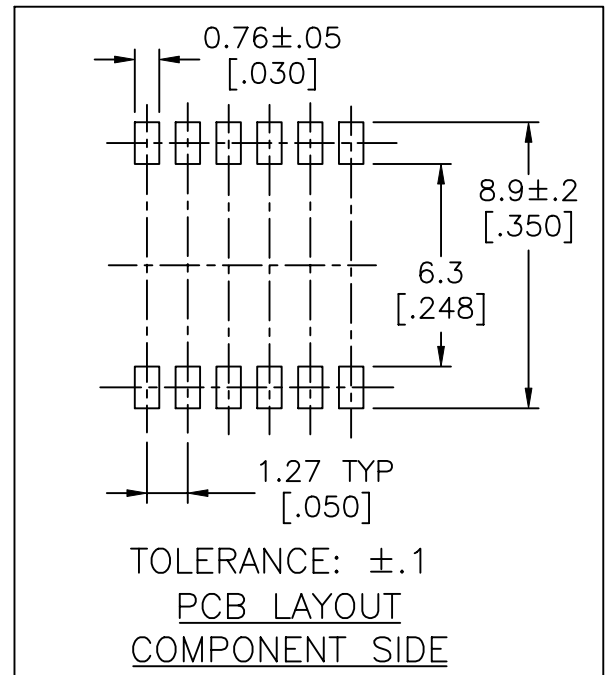
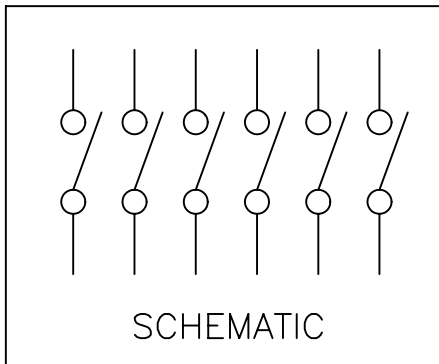

POLE	2P	4P	6P	8P	10P	12P
A	3.70 [0.146]	6.20 [0.244]	8.75 [0.344]	11.30 [0.445]	13.80 [0.543]	16.35 [0.644]

NOTES: 2P & 4P NO MARKINGS.
FOR 2P - TAPE AND REEL PACKAGING ONLY.

DESIGNED:	DRAWN:	CHECKED:	APPROVED:	SYM.	DATE:	DESCRIPTION OF REVISIONS:	DRAWN	APPD.
	GAT	GAT	JF	▲	08/28/06	NEW	GAT	JF
				▲	.	.		
				▲	.	.		
				▲	.	.		

3RD ANGLE

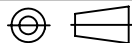

UNIT:

mm[IN]

SCALE:

4:1

REV.

A



TOLERANCE:

TO 1 DECIMAL PLACE:	±.3
TO 2 DECIMAL PLACES:	±.2
AS ANGLES:	±1/2°

SHEET:

PART NO:

SRHS1XX

TITLE:

HALF PITCH SMT
DIP SWITCH

1 OF 2

COMPONENT SPECIFICATION

USE OR REPRODUCTION OF THIS DRAWING FOR THE PURPOSE OF MANUFACTURING THIS ARTICLE OR ANY ARTICLES SHOWN FOR ANY PURPOSE IS STRICTLY PROHIBITED WITHOUT WRITTEN PERMISSION FROM SENIOR INDUSTRIES, INC.

SPECIFICATIONS

ELECTRICAL:

CIRCUIT TYPE: SPST
 CONTACT RATING:
 SWITCHING: 25mA @ 24 VDC
 NON-SWITCHING: 100mA
 CONTACT RESISTANCE: 100 MILLIOHMS MAX.
 INSULATION RESISTANCE: 500 MEGOHMS MIN. AT 100 VDC
 DIELECTRIC STRENGTH: 300 VRMS MIN. FOR 1 MINUTE

MECHANICAL:

LIFE: 1000 CYCLES MIN.
 OPERATION FORCE: 500g MAX.

ENVIRONMENTAL:

OPERATING TEMPERATURE: -25°C TO 70°C
 STORAGE TEMPERATURE: -40°C TO +85°C
 PART SHALL WITHSTAND REFLOW SOLDER TEMPERATURE OF 260°C FOR 10 SECONDS.

MATERIAL:



COVER: POLYAMIDE, BLACK, UL94V-0
 BASE: POLYAMIDE, BLACK, UL94V-0
 KNOB: POLYAMIDE, WHITE, UL94V-0
 TERMINAL: BRASS ALLOY, GOLD PLATING
 FIXED CONTACT: BRASS ALLOY, GOLD PLATING
 MOVABLE CONTACT: BERYLLIUM COPPER, GOLD PLATING



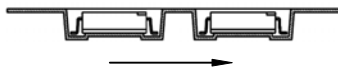

PACKAGING:

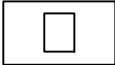
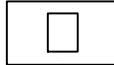
TAPE WIDTH: 16mm FOR 2P, 4P, 6P
 24mm FOR 8P, 10P, 12P
 TAPE PITCH: 12mm
 REEL SIZE: 330mm DIA.
 COMPONENT LOAD: 2000 PCS PER REEL
 DIRECTION OF FEED:



PART NUMBER BUILDER:

MODEL	TYPE	POSITIONS	ACTUATOR
SRHS			
	1=SPST	02 04 06 08 10 12	L =FLUSH LT =FLUSH WITH TOP TAPE SEALED LR =FLUSH AND TAPE&REEL LTR=FLUSH WITH TOP TAPE SEALED AND TAPE&REEL

DESIGNED:	DRAWN:	CHECKED:	APPROVED:	SYM.	DATE:	DESCRIPTION OF REVISIONS:	DRAWN	APPD.
	GAT	GAT	JF		08.28.06	NEW	GAT	JF
					. . .			
					. . .			
					. . .			

3RD ANGLE

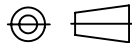

UNIT:

mm[IN]

SCALE:

REV.

A



SENIOR INDUSTRIES, INC.

TOLERANCE:

TO 1 DECIMAL PLACE:	±
TO 2 DECIMAL PLACES:	±
AS ANGLES:	± °

SHEET:

PART NO:

SRHS1XX

TITLE:

HALF PITCH SMT
DIP SWITCH

2 OF 2