

1 | 2 | 3 | 4

COMPONENT SPECIFICATION

USE OR REPRODUCTION OF THIS DRAWING FOR THE PURPOSE OF MANUFACTURING THIS ARTICLE OR ANY ARTICLES SHOWN FOR ANY PURPOSE IS STRICTLY PROHIBITED WITHOUT WRITTEN PERMISSION FROM SENIOR INDUSTRIES, INC.

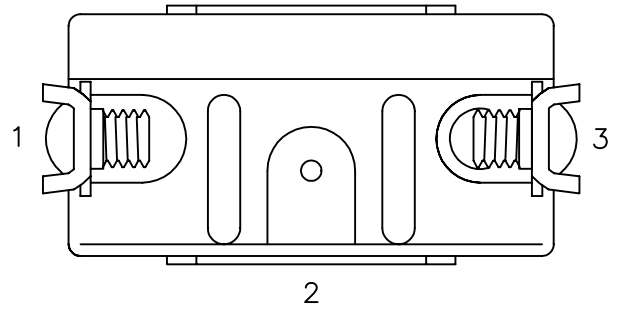
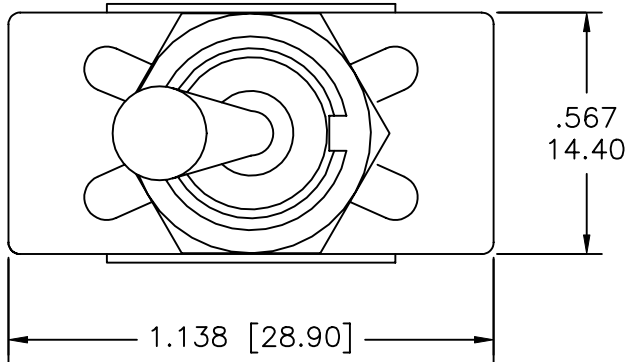

MODEL NO.	SWITCHING POSITION		
7710	ON	NONE	OFF
7711	MOM	NONE	OFF
CONN. TERMS	1-3	NONE	OPEN
NO. POLES	SPST		

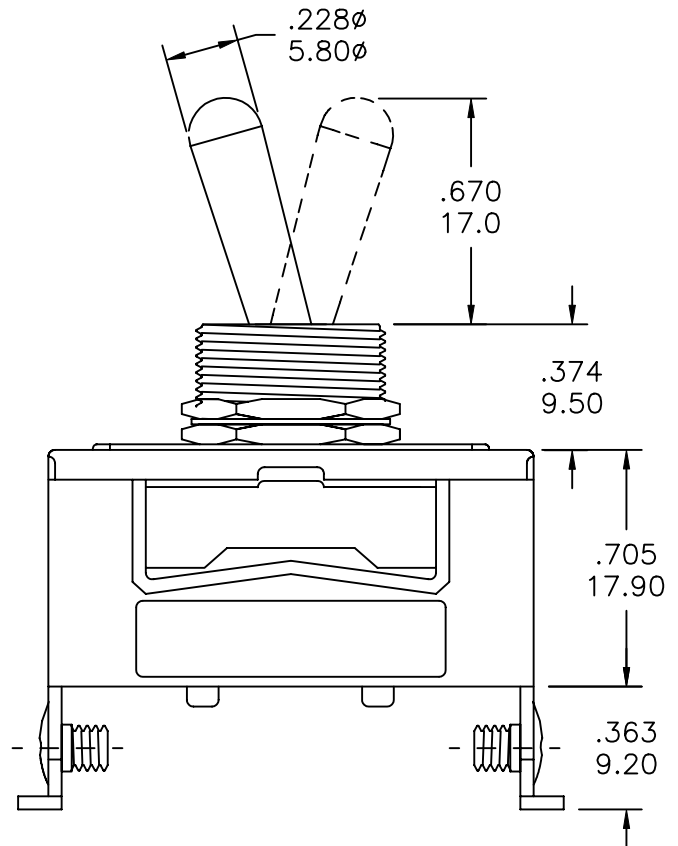

NOTE: RUBBER BOOT AVAILABLE, SR PART NUMBER: SRLT-RB.

DESIGNED:			SYM.	DATE	DESCRIPTION OF REVISIONS	DRAWN	APPD.
DRAWN:	RT	10/10/01	▲	10.10.01	NEW	RB	JF
CHECKED:	GAT	10/27/05	▲	10.18.05	New Index, Note added, gen dwg/spec updated	GAT	JF
APPROVED:	JF	10/27/05	▲	.			

3RD ANGLE		UNIT: mm	SCALE: 2:1	REV.	B
-----------	--	----------	------------	------	---



TOLERANCE:	PART NO:
TO 1 DECIMAL PLACE: ±.2	SEE CHART
TO 2 DECIMAL PLACES: ±.10	TITLE: SRLT-7710/7711
AS ANGLES: ±1/2°	TOGGLE SWITCHES
SHEET:	1 OF 4

COMPONENT
SPECIFICATIONUSE OR REPRODUCTION OF THIS DRAWING FOR THE PURPOSE OF MANUFACTURING THIS
ARTICLE OR ANY ARTICLES SHOWN FOR ANY PURPOSE IS STRICTLY PROHIBITED WITHOUT
WRITTEN PERMISSION FROM SENIOR INDUSTRIES, INC.SPECIFICATIONSELECTRICAL

CONTACT RATING: 15A @ 250 VAC, 20A @ 125 VAC
 CONTACT RESISTANCE: 20 MILLIOHMS MAX.
 INSULATION RESISTANCE: 200 MEGOHMS MIN. AT 500 VDC
 DIELECTRIC STRENGTH: 1,500 VAC FOR 1 MINUTE

MECHANICAL

LIFE: 40,000 CYCLES

ENVIRONMENTAL

OPERATING TEMPERATURE: -30°C TO +85°C





MATERIAL



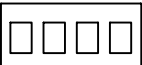

ACTUATOR: BRASS, CHROME PLATED
 BUSHING: BRASS, NICKEL PLATED
 SUPPORT: BRASS, TIN PLATED
 CONTACT: SILVER ALLOY
 TERMINALS: H1/H2 - BRASS, NICKEL PLATED
 H3 - BRASS, TIN PLATED
 H4/H5 - BARE BRASS

REGULATORY:

UL AND CANADA RECOGNIZED COMPONENT. UL/CUL FILE NO. E173084.

PART NUMBER BUILDER:

SERIES	MODEL NO.	CASE	ACTUATOR	BUSHING	TERMINATION
SRLT -		- 			
	7710	M (METAL)	T1	B1	H1 (SCREW/SHORT)
	7711	P (PLASTIC)	T2	B2	H2 (SCREW/LONG)
			T3	B3	H3 (SOLDER)
			T4	B4	H4 (FLAT)
					H5

DESIGNED:			SYM.	DATE	DESCRIPTION OF REVISIONS	DRAWN	APPD.
DRAWN:	RT	10/10/01		10.10.01	NEW	RB	JF
CHECKED:	GAT	10/27/05		10.18.05	New Index, Note added, gen dwg/spec updated	GAT	JF
APPROVED:	JF	10/27/05		.			
				.			

3RD ANGLE

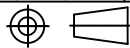

UNIT:

mm

SCALE:

REV.

B

**SENIOR
INDUSTRIES, INC.**

TOLERANCE:

TO 1 DECIMAL PLACE: ±

TO 2 DECIMAL PLACES: ±

AS ANGLES: ±

SHEET:

PART NO:

SEE CHART

TITLE:

SRLT-7710/7711
TOGGLE SWITCHES

2 OF 4

1

2

3

4

COMPONENT
SPECIFICATIONUSE OR REPRODUCTION OF THIS DRAWING FOR THE PURPOSE OF MANUFACTURING THIS
ARTICLE OR ANY ARTICLES SHOWN FOR ANY PURPOSE IS STRICTLY PROHIBITED WITHOUT
WRITTEN PERMISSION FROM SENIOR INDUSTRIES, INC.

A

ACTUATOR OPTIONS

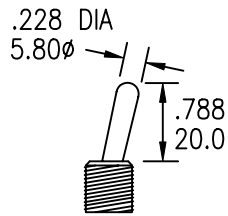

T1

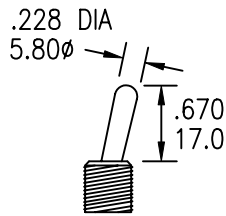

T2

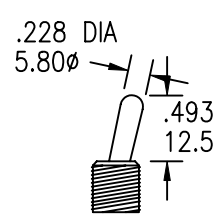

T3

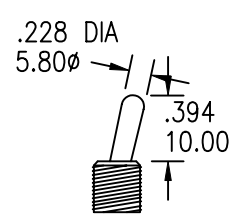

T4

B

BUSHING OPTIONS

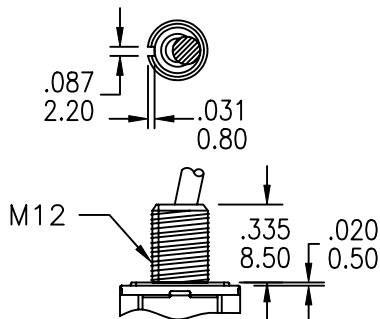

B1

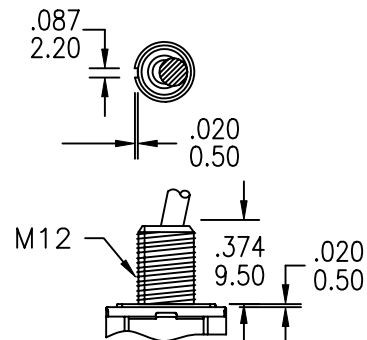

B2

C

D

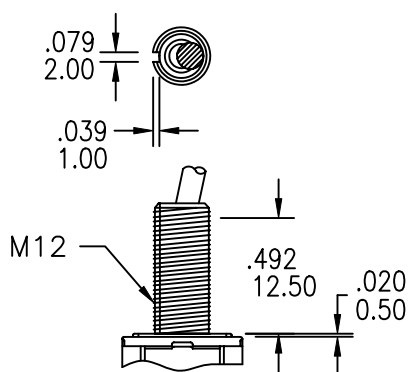

B3

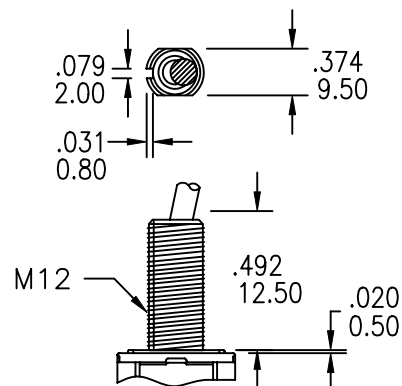

B4

E

DESIGNED:			SYM.	DATE	DESCRIPTION OF REVISIONS	DRAWN	APPD.
DRAWN:	RT	10/10/01	△	10.10.01	NEW	RB	JF
CHECKED:	GAT	10/27/05	△	10.18.05	New Index, Note added, gen dwg/spec updated	GAT	JF
APPROVED:	JF	10/27/05	△				

3RD ANGLE

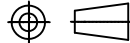

UNIT:

mm

SCALE:

REV.

B

**SENIOR
INDUSTRIES, INC.**

TOLERANCE:

TO 1 DECIMAL PLACE: ±.2

TO 2 DECIMAL PLACES: ±.10

AS ANGLES: ±1/2°

SHEET:

PART NO:

SEE CHART

TITLE:

 SRLT-7710/7711
 TOGGLE SWITCHES

3 OF 4

1

2

3

4

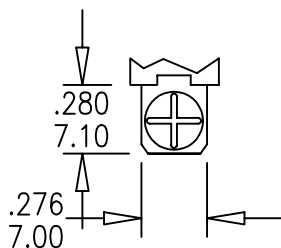
COMPONENT
SPECIFICATIONUSE OR REPRODUCTION OF THIS DRAWING FOR THE PURPOSE OF MANUFACTURING THIS
ARTICLE OR ANY ARTICLES SHOWN FOR ANY PURPOSE IS STRICTLY PROHIBITED WITHOUT
WRITTEN PERMISSION FROM SENIOR INDUSTRIES, INC.TERMINATION OPTIONS

H1 (SCREW/SHORT)

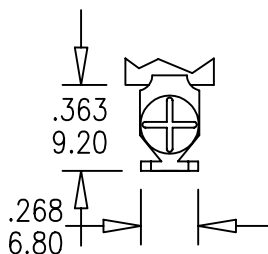

H2 (SCREW/LONG)

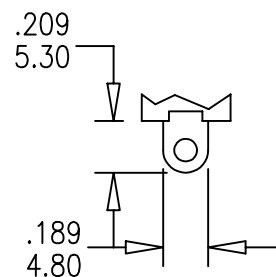

H3 (SOLDER)

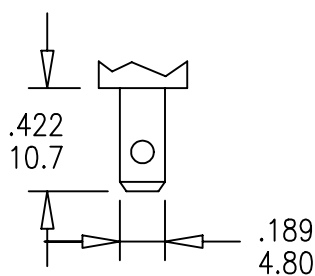

H4 (FLAT/STRAIGHT)

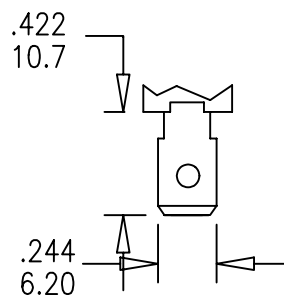

H5 (FLAT/ANGLED)

DESIGNED:

SYM.

DATE

DESCRIPTION OF REVISIONS

DRAWN

APPD.

DRAWN:

RT

10/10/01



10.10.01

NEW

RB

JF

CHECKED:

GAT

10/27/05



10.18.05

New Index, Note added, gen dwg/spec updated

GAT

JF

APPROVED:

JF

10/27/05



.

.



.

.

3RD ANGLE

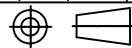

UNIT:

mm

SCALE:

REV.

B

**SENIOR
INDUSTRIES, INC.**

TOLERANCE:

TO 1 DECIMAL PLACE: $\pm .2$ TO 2 DECIMAL PLACES: $\pm .10$ AS ANGLES: $\pm 1/2^\circ$

SHEET:

PART NO:

SEE CHART

TITLE:

SRLT-7710/7711
TOGGLE SWITCHES

4 OF 4