

UNLESS OTHERWISE SPECIFIED, ALL DIMENSIONS ARE IN INCHES [MM].

TO 1 DECIMAL PLACE ±.2  
 TO 2 DECIMAL PLACES ±.10  
 AS ANGLES ±

ISSUE	DATE
A	03/15/01
B	03/27/01

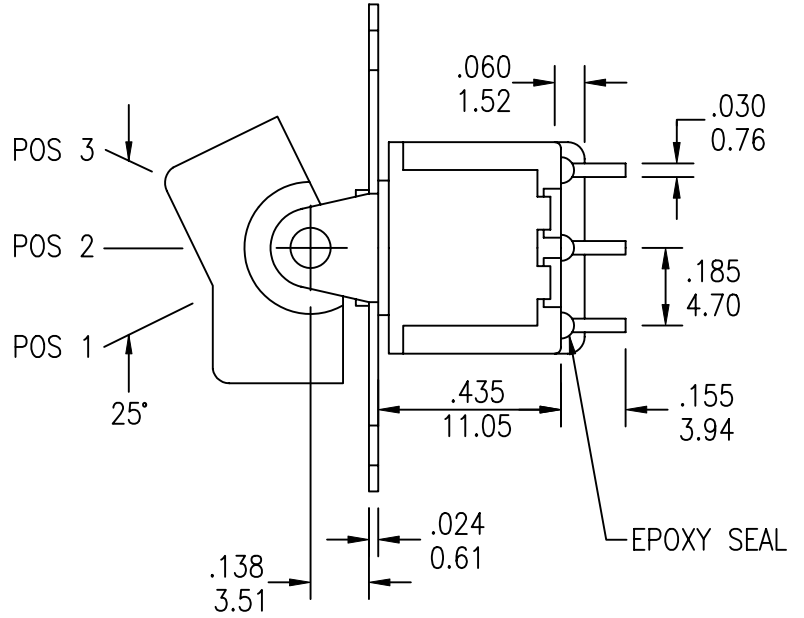
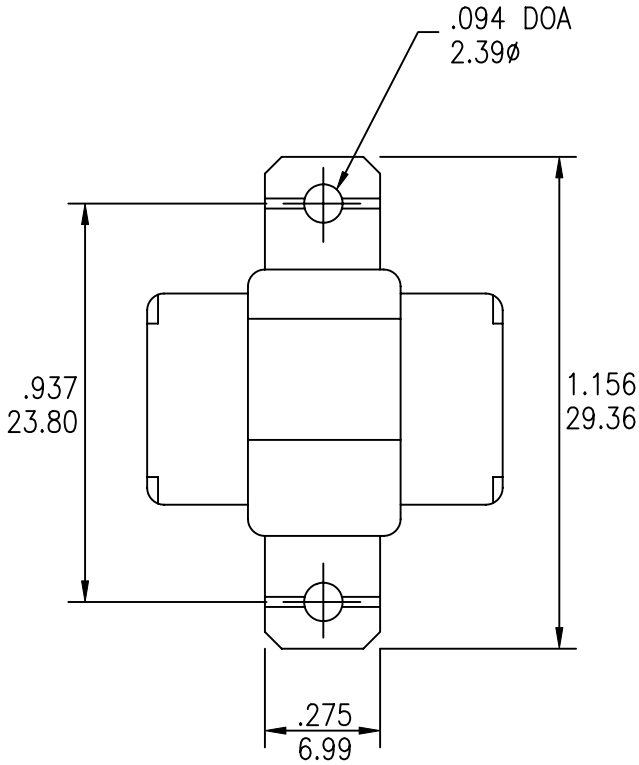

MODEL NO.	SWITCHING POSITION		
8401	ON	NONE	ON
8403	ON	NONE	MOM
8405	ON	OFF	ON
8407	MOM	OFF	MOM
8409	ON	OFF	MOM
CONN. TERMS	2-3, 5-6 8-9, 11-12	OPEN	2-1, 5-4 8-7, 11-10
SCHEMATIC			

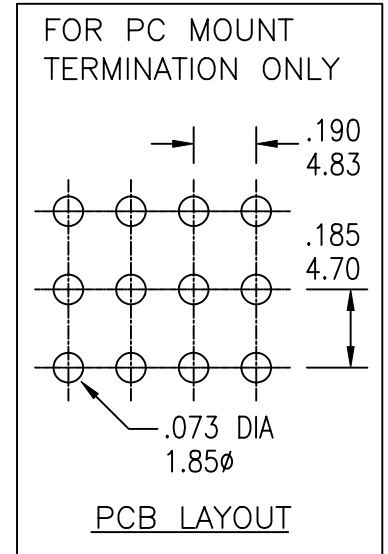

UNLESS OTHERWISE SPECIFIED, ALL DIMENSIONS ARE IN INCHES [MM].  
 TO 1 DECIMAL PLACE ±.2  
 TO 2 DECIMAL PLACES ±.10  
 AS ANGLES ±

ISSUE	DATE
A	03/15/01
B	03/27/01

SPECIFICATIONS

ELECTRICAL

CONTACT RATING:

SILVER: 5A @ 120 VAC OR 28 VDC, 2A @ 250 VAC  
 GOLD: 0.4 VA MAX. @ 20 V MAX. (AC OR DC)

CONTACT RESISTANCE: 10 MILLIOHMS MAX.

INSULATION RESISTANCE: 1,000 MEGOHMS MIN. AT 500 VDC

DIELECTRIC STRENGTH: 1,000 VRMS

MECHANICAL

LIFE: 50,000 CYCLES

ENVIRONMENTAL

OPERATING TEMPERATURE: -30°C TO +85°C

MATERIAL

CASE: DAP, UL 94V-0

HOUSING: STAINLESS STEEL

ACTUATOR: NYLON

BUSHING: BRASS, NICKEL PLATED

SUPPORT: BRASS, TIN PLATED

CONTACT/TERMINALS: COPPER ALLOY, SILVER OR GOLD PLATED

REGULATORY

UL RECOGNIZED COMPONENT. UL FILE NO. E173084.

SERIES	MODEL NO.	ACTUATOR	ACTUATOR COLOR	TERMINATION	CONTACT PLATING	SEAL
SRMR	□□□□□	□	□	□	□	□
	8401	R11 (ROCKER)	1 - BLUE		Q (SILVER)	BLANK
	8403	R12 (ROCKER W/BEZEL)	2 - RED		R (GOLD)	E (EPOXY)
	8405	R15 (LARGE ROCKER)	3 - BLACK			
	8407	P13 (PADDLE)	4 - BROWN	B (SOLDER LUG)		
	8409	P14 (PADDLE W/BEZEL)	5 - GREEN	C (PC MOUNT)		
		P16 (LARGE PADDLE)	6 - WHITE	D (QUICK CONNECT)		
			7 - GRAY	D1 (WIRE WRAP - .750)		
			8 - ORANGE	D2 (WIRE WRAP - .964)		
			9 - YELLOW	D3 (WIRE WRAP - .425)		
			0 - VIOLET	D4 (WIRE WRAP - 1.062)		



TITLE: ROCKER AND PADDLE SWITCHES			PART NO: SRMR-84XX-XXXXX		
DATE: 03/05/01	DRAWN: RB	CHKD:	SCALE: N/A	SHEET: 2 OF 5	

UNLESS OTHERWISE SPECIFIED, ALL DIMENSIONS ARE IN INCHES [MM].

TO 1 DECIMAL PLACE ±.2  
 TO 2 DECIMAL PLACES ±.10  
 AS ANGLES ±

ISSUE	DATE
A	03/15/01
B	03/27/01

ACTUATOR OPTIONS

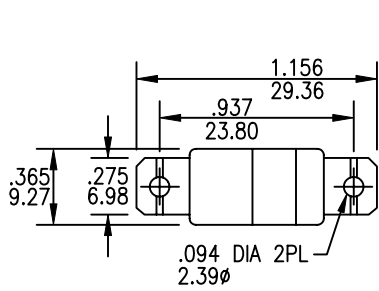

R11

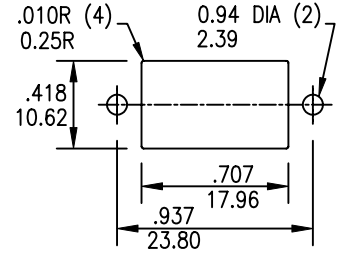
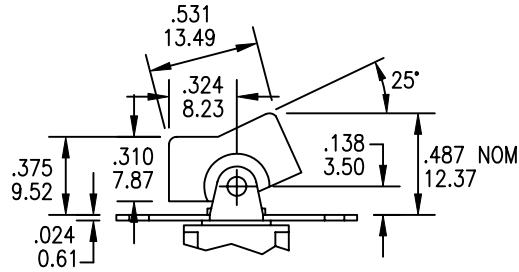

PANEL MOUNTING

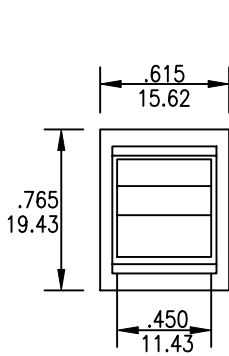

R12

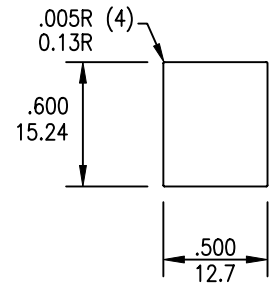
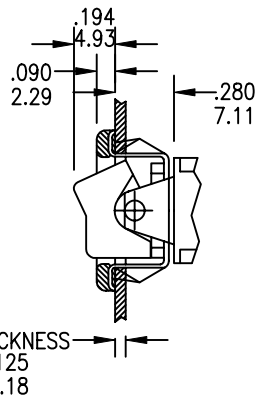

PANEL MOUNTING

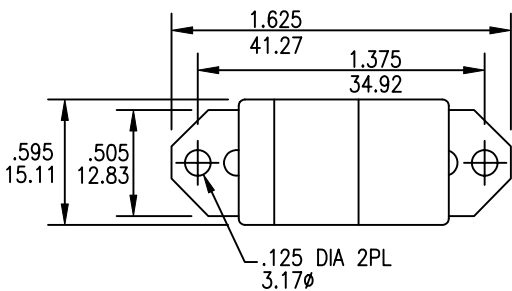

R15

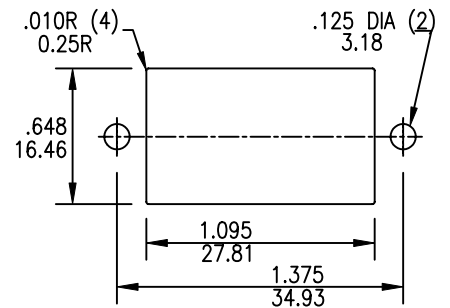
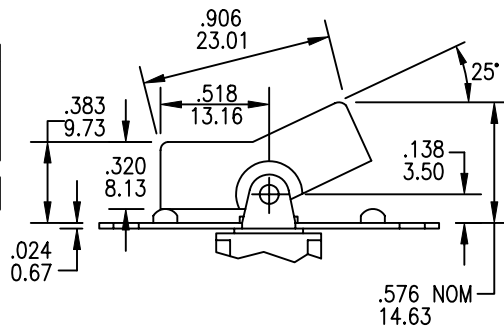

PANEL MOUNTING

UNLESS OTHERWISE SPECIFIED, ALL DIMENSIONS ARE IN INCHES [MM].

TO 1 DECIMAL PLACE ±.2  
 TO 2 DECIMAL PLACES ±.10  
 AS ANGLES ±

ISSUE	DATE
A	03/15/01
B	03/27/01

ACTUATOR OPTIONS

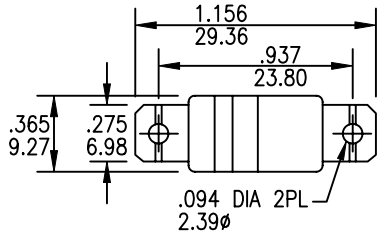

P13

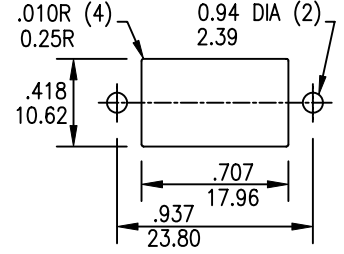
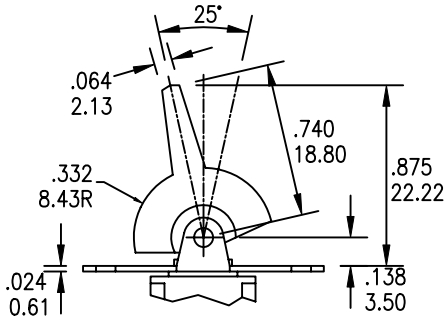

PANEL MOUNTING

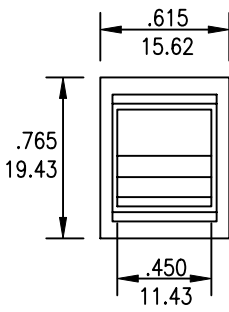

P14

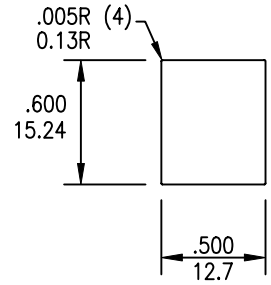
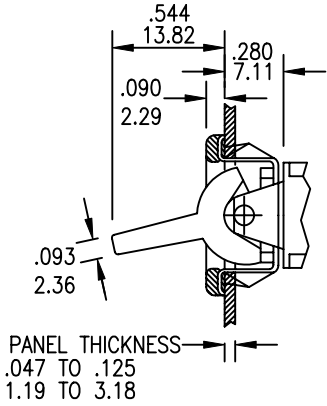

PANEL MOUNTING

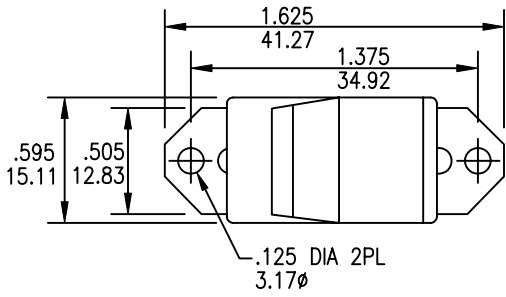

P16

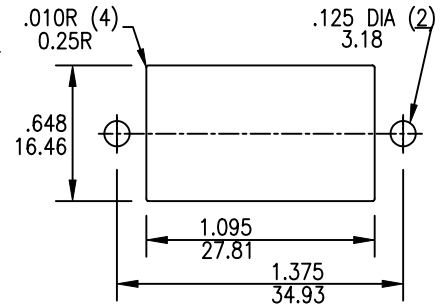
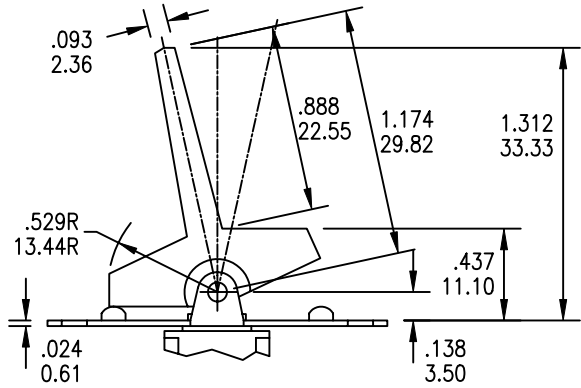

PANEL MOUNTING



TITLE: ROCKER AND PADDLE SWITCHES

PART NO: SRMR-84XX-XXXXX

DATE: 03/05/01

DRAWN: RB

CHKD:

SCALE: N/A

SHEET: 4 OF 5

UNLESS OTHERWISE SPECIFIED, ALL DIMENSIONS ARE IN INCHES [MM].

TO 1 DECIMAL PLACE ±.2  
 TO 2 DECIMAL PLACES ±.10  
 AS ANGLES ±

ISSUE	DATE
A	03/15/01
B	03/27/01

TERMINATION OPTIONS

SOLDER LUG

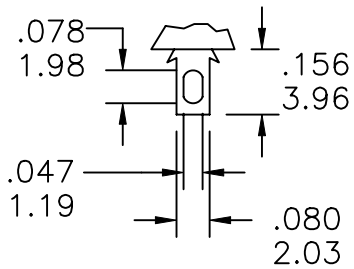

B

PC MOUNT

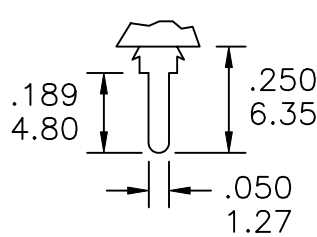

C

QUICK CONNECT

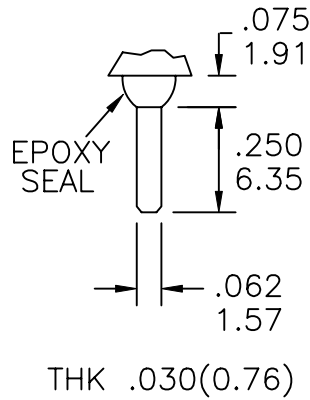

D

WIRE WRAP

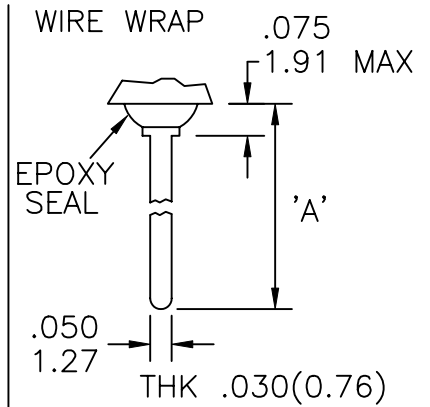

	'A'
D1	.750(19.05)
D2	.964(24.48)
D3	.425(10.80)
D4	1.062(26.97)