

UNLESS OTHERWISE SPECIFIED, ALL DIMENSIONS ARE IN INCHES [MM].

TO 1 DECIMAL PLACE ±.2
 TO 2 DECIMAL PLACES ±.10
 AS ANGLES ±

ISSUE	DATE
A	03/05/01
B	09/29/04
C	02/14/08

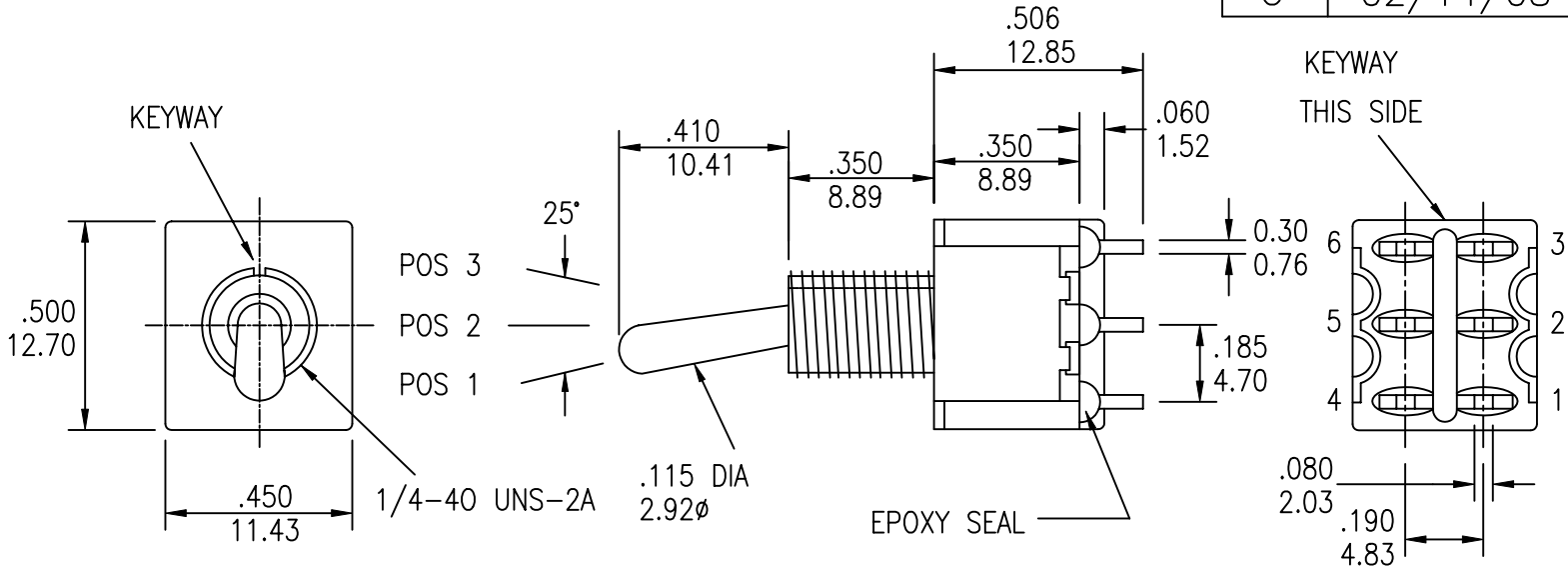

SRMT-8011-SEBQE SHOWN

MODEL NO.	SWITCHING POSITION		
8011	ON	NONE	ON
8011A	ON	NONE	MOM
8012	ON	OFF	ON
8012A	MOM	OFF	MOM
8012B	ON	OFF	MOM
8012C	ON	ON	ON
CONN. TERMS	2-3 5-6	OPEN	2-1 5-4
SCHEMATIC	<p>DPDT 2 Comm. 5 Comm.</p>		

NON-SHORTING TYPE

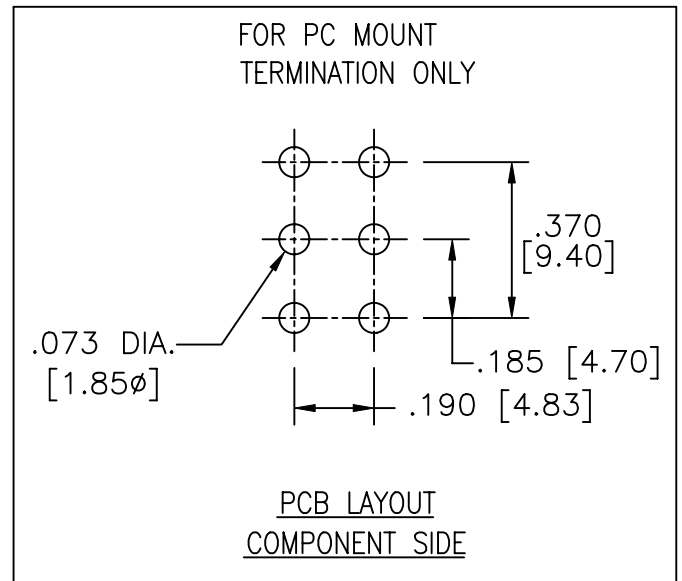

TITLE: SRMT 8011/8012 TOGGLE SWITCHES

PART NO: SEE CHART

DATE: 03/05/01

DRAWN: RB

CHKD:

SCALE: 2/1

SHEET: 1 OF 6

UNLESS OTHERWISE SPECIFIED, ALL DIMENSIONS ARE IN INCHES [MM].

TO 1 DECIMAL PLACE ±.2
 TO 2 DECIMAL PLACES ±.10
 AS ANGLES ±

ISSUE	DATE
A	03/05/01
B	09/29/04
C	02/14/08

SPECIFICATIONS

ELECTRICAL

CONTACT RATING:

SILVER: 5A @ 120 VAC OR 28 VDC, 2A @ 250 VAC

GOLD: 0.4 VA MAX. @ 20 V MAX. (AC OR DC)

CONTACT RESISTANCE: 10 MILLIOHMS MAX.

INSULATION RESISTANCE: 1,000 MEGOHMS MIN. AT 500 VDC

DIELECTRIC STRENGTH: 1,000 VRMS

MECHANICAL

LIFE: 40,000 CYCLES

ENVIRONMENTAL

OPERATING TEMPERATURE: -30°C TO +85°C

MATERIAL

CASE: DAP, UL94V-0

HOUSING: STAINLESS STEEL

ACTUATOR: BRASS, CHROME PLATED

BUSHING: BRASS, NICKEL PLATED

SUPPORT: BRASS, TIN PLATED

CONTACT/TERMINALS: COPPER ALLOY, SILVER OR GOLD PLATED

REGULATORY

UL AND CANADA RECOGNIZED COMPONENT. UL/CUL FILE NO. E173084.

PART NUMBER BUILDER:

SERIES	MODEL NO.	ACTUATOR	BUSHING	TERMINATION	CONTACT PLATING	SEAL	VERTICAL SUPPORT BRACKET
SRMT -	<input type="text"/>	- <input type="text"/>	<input type="text"/>	<input type="text"/>	<input type="text"/>	<input type="text"/>	<input type="text"/>
	8011	S (STD)	BLANK (Z/Z1 ONLY)		Q (SILVER)	BLANK	BLANK
	8011A	T	E (STD - THD)		R (GOLD)	E (EPOXY)	S20
	8012	X (LONG)	E1 (STD - THD) (U ONLY)	B (SOLDER LUG) C (PC MOUNT) D (QUICK CONNECT) D1 (WIRE WRAP - .736) D2 (WIRE WRAP - .953) D3 (WIRE WRAP - .415) D4 (WIRE WRAP - 1.062)			S30
	8012A	W (LONG)	E2 (STD - THD) (U ONLY)				S40
	8012B	V (LONG)	M (STD - NON-THD)				S50
	8012C	U (FLATTED)	M1 (STD - NON-THD)(U ONLY)				
		Z (LARGE TOGGLE)	M2 (STD - NON-THD)(U ONLY)				
		Z1 (LARGE)	F (THD)				
		Y (PLASTIC)	N (NON-THD)				
		LL1 (LOCKING LEVER)	G (HIGH TORQUE)				
			H (HIGH TORQUE)				
			J (LONG)				
			K (METRIC)				
			L (SPLASH-PROOF)				



TITLE: SRMT 8011/8012 TOGGLE SWITCHES

PART NO: SEE CHART

DATE: 03/05/01

DRAWN: RB

CHKD:

SCALE: N/A

SHEET: 2 OF 6

UNLESS OTHERWISE SPECIFIED, ALL DIMENSIONS ARE IN INCHES [MM].

TO 1 DECIMAL PLACE ±.2
 TO 2 DECIMAL PLACES ±.10
 AS ANGLES ±

ISSUE	DATE
B	09/29/04
C	02/14/08

ACTUATOR OPTIONS

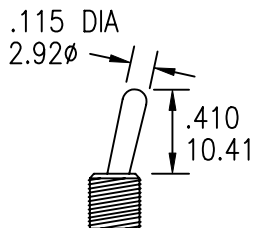

S (STD)

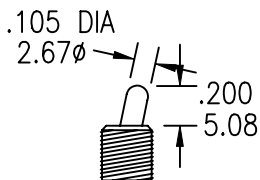

T

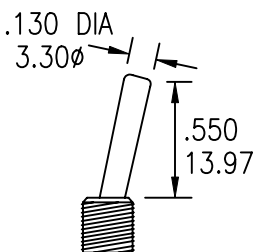

X (LONG)

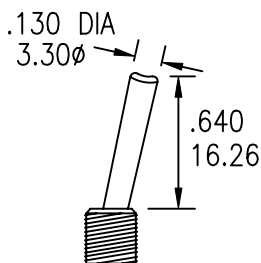

V (LONG)

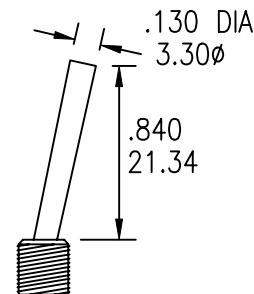

W (LONG)

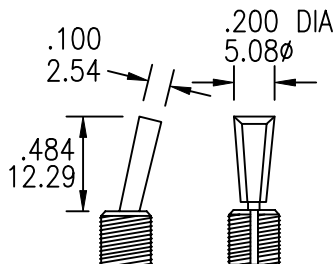

U (FLATTED)

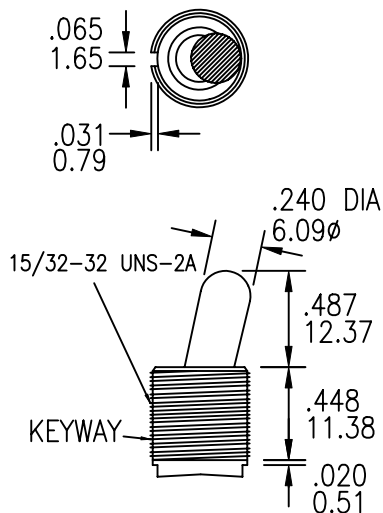

Z (LARGE TOGGLE)

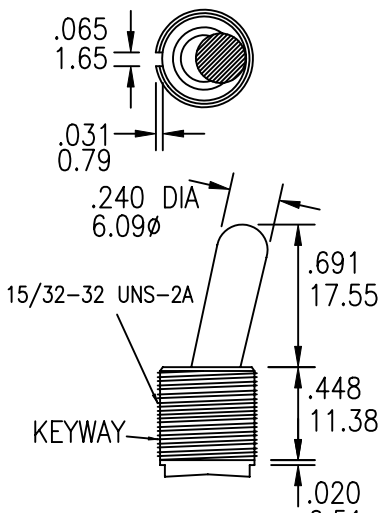

Z1

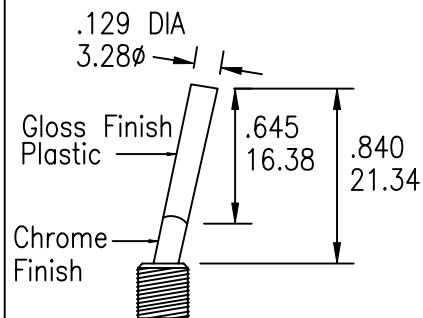

Y (PLASTIC)

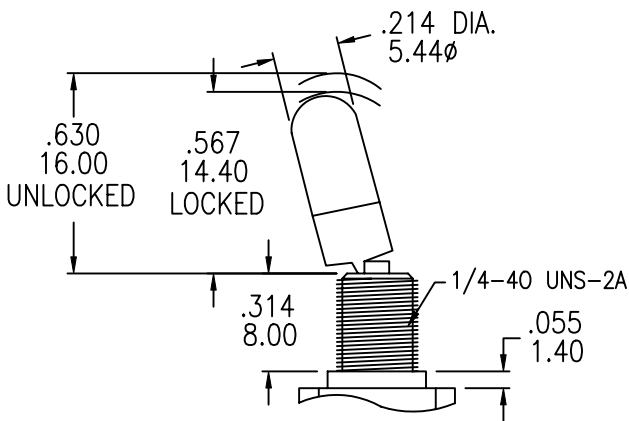

LL1 (LOCKING LEVER)

NOTE: OPTIONAL TOGGLE CAP AVAILABLE.

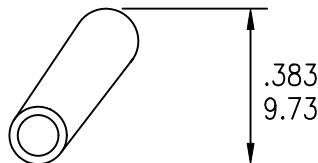

STD FOR S OPTION

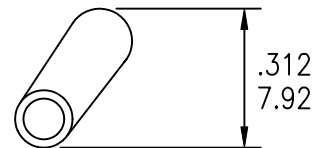

STD FOR T OPTION

UNLESS OTHERWISE SPECIFIED, ALL DIMENSIONS ARE IN INCHES [MM].

TO 1 DECIMAL PLACE ±.2
 TO 2 DECIMAL PLACES ±.10
 AS ANGLES ±

ISSUE	DATE
A	03/05/01
B	09/29/04
C	02/14/08

BUSHING OPTIONS

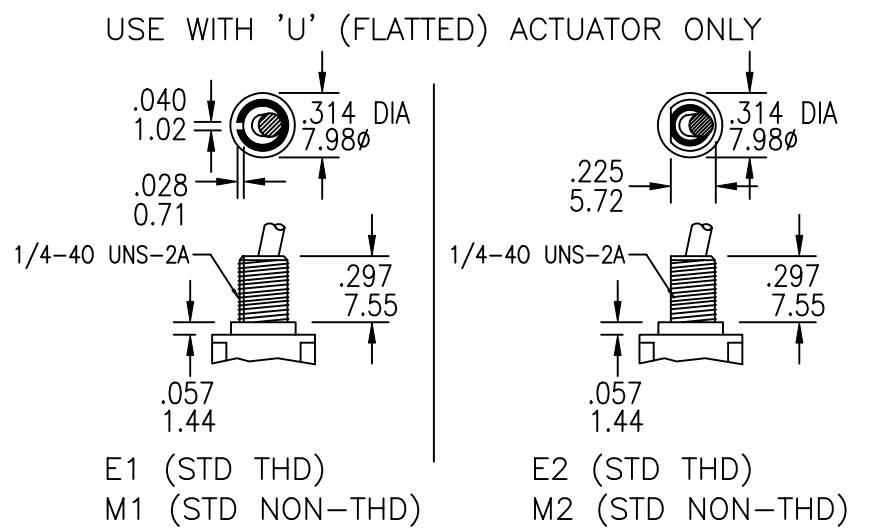
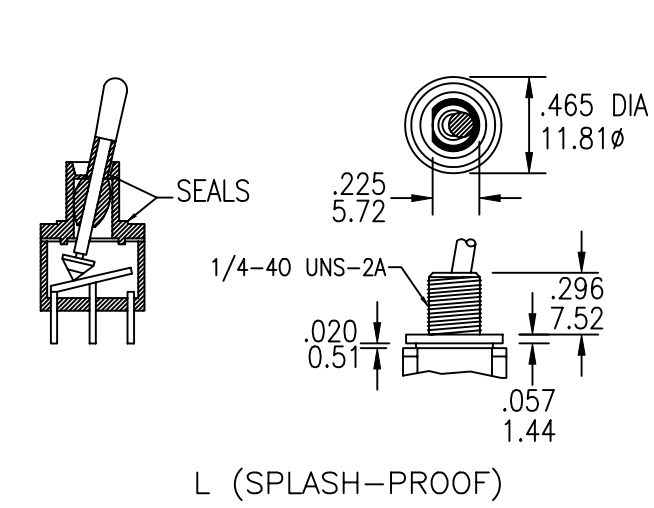
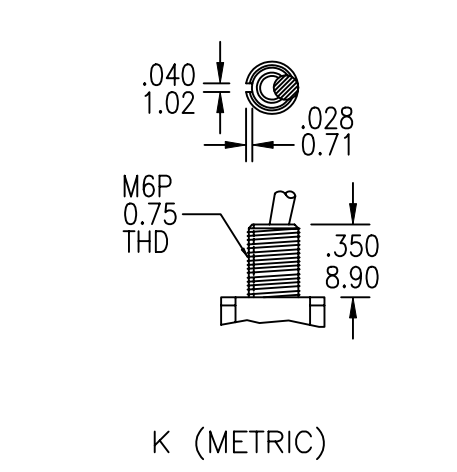
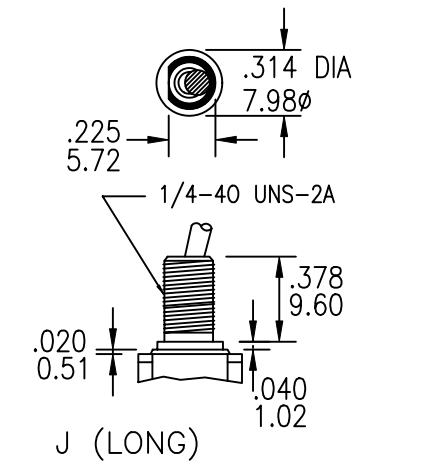
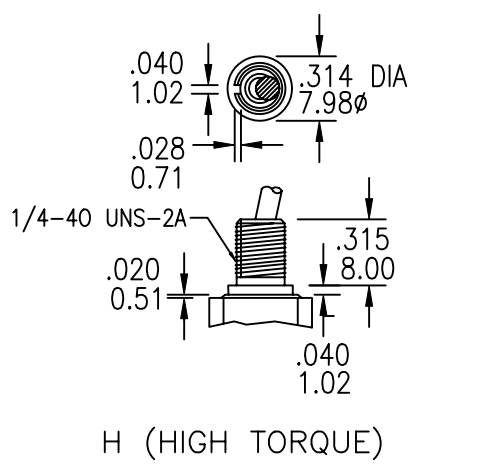
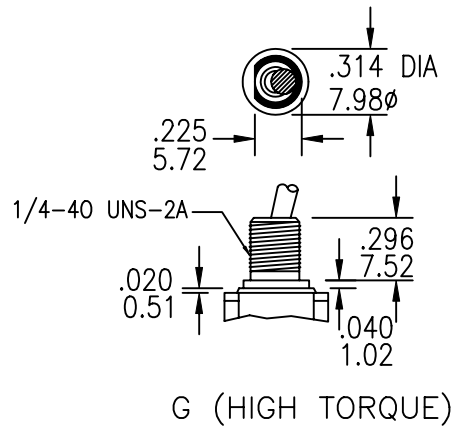
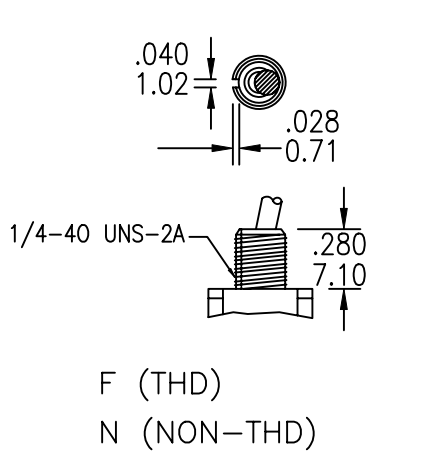
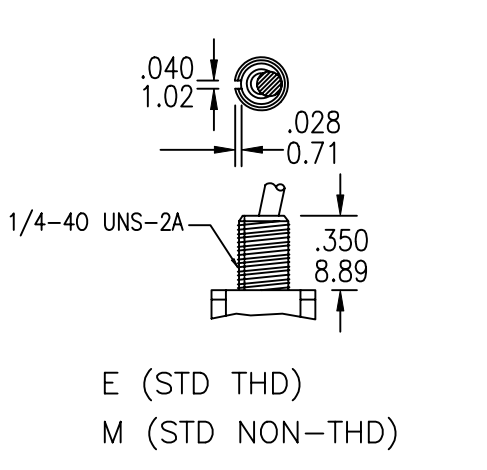

UNLESS OTHERWISE SPECIFIED, ALL DIMENSIONS ARE IN INCHES [MM].

TO 1 DECIMAL PLACE ±.2
 TO 2 DECIMAL PLACES ±.10
 AS ANGLES ±

ISSUE	DATE
A	03/05/01
B	09/29/04
C	02/14/08

TERMINATION OPTIONS

SOLDER LUG

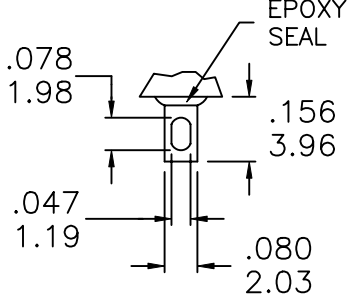

B

PC MOUNT

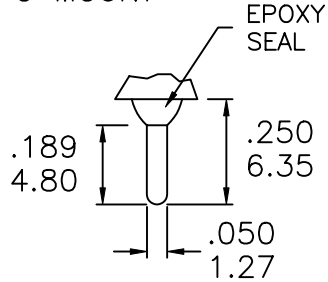

.030 [0.76] THK

C

QUICK CONNECT

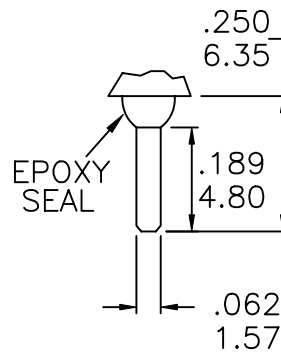

.030 [0.76] THK

D

WIRE WRAP

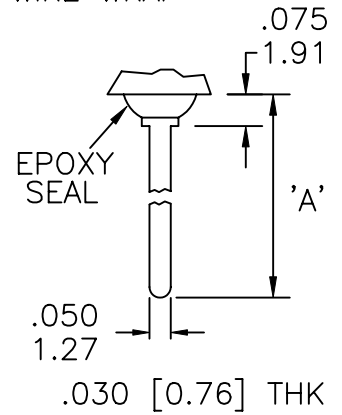

	'A'
D1	.736(18.70)
D2	.953(24.20)
D3	.415(10.54)
D4	1.062(26.97)

VERTICAL SUPPORT BRACKET OPTIONS

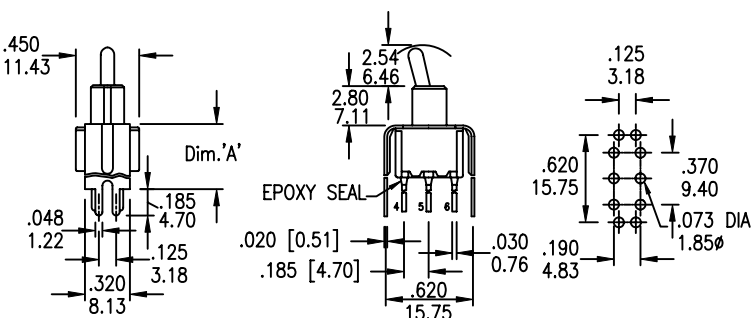

	'A'
S20	.460 [11.68]
S30	.630 [16.00]

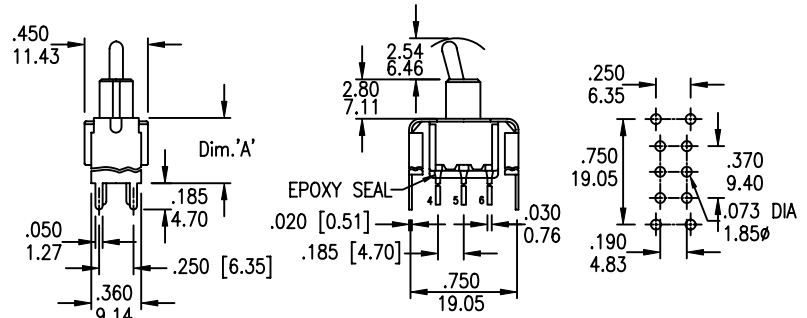

	'A'
S40	.460 [11.68]
S50	.630 [16.00]

UNLESS OTHERWISE SPECIFIED, ALL DIMENSIONS ARE IN INCHES [MM].

TO 1 DECIMAL PLACE ±.2
 TO 2 DECIMAL PLACES ±.10
 AS ANGLES ±

ISSUE	DATE
B	09/29/04
C	02/14/08

STANDARD NUTS

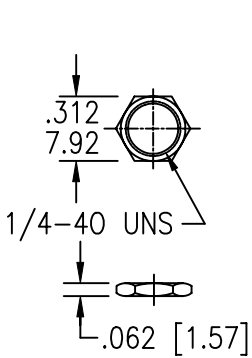

STD FOR E, F, G,
H, AND L OPTIONS

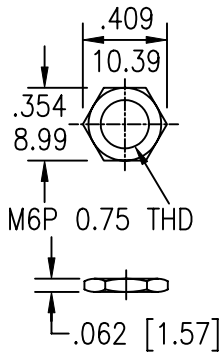

STD FOR K OPTION

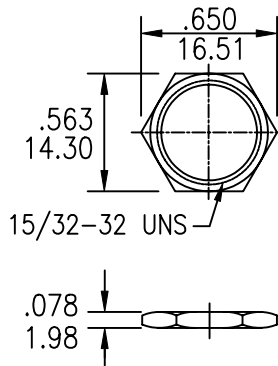

STD FOR Z
AND Z1 OPTIONS

OPTIONAL NUTS

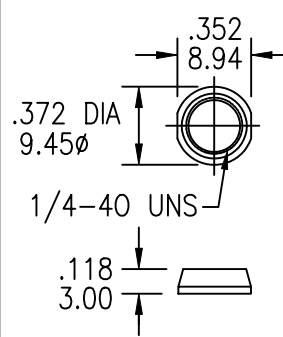

DRESS NUT

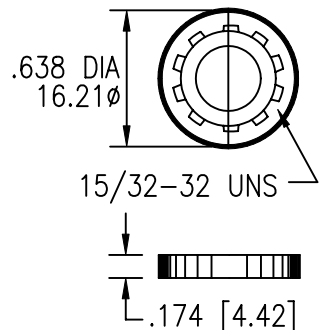

KNURLED

LOCK WASHER

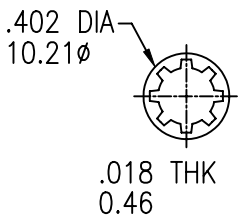

STD FOR E AND F

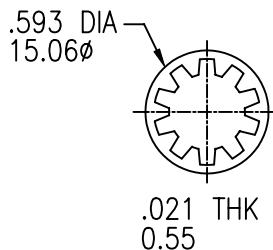

STD FOR Z AND Z1 OPTIONS

LOCKING RING

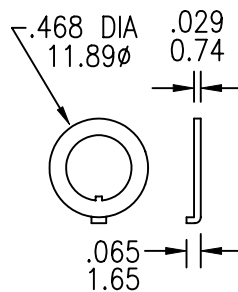

STD

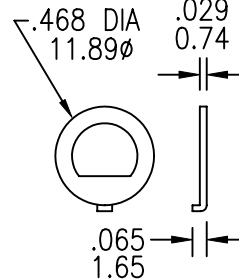

STD FOR G
AND J OPTIONS.

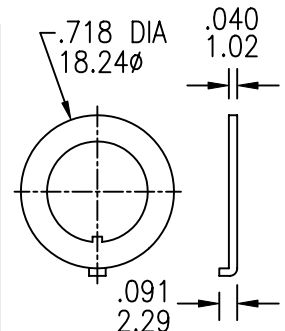

STD FOR Z
AND Z1 OPTIONS.

PANEL MOUNTING

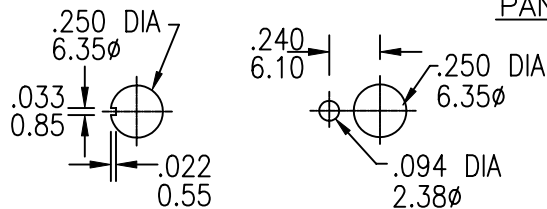

FOR BUSHING E, M, F, N, AND H OPTIONS

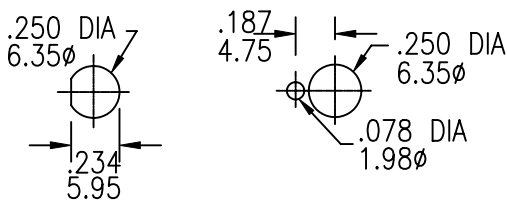

FOR BUSHING G, J, AND L OPTIONS

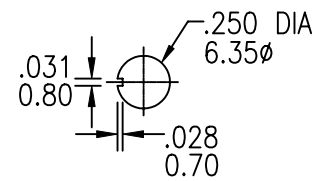

FOR BUSHING K OPTION

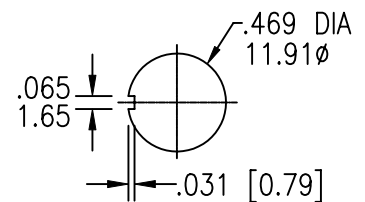

FOR ACTUATOR Z AND Z1 OPTIONS