

COMPONENT SPECIFICATION

USE OR REPRODUCTION OF THIS DRAWING FOR THE PURPOSE OF MANUFACTURING THIS ARTICLE OR ANY ARTICLES SHOWN FOR ANY PURPOSE IS STRICTLY PROHIBITED WITHOUT WRITTEN PERMISSION FROM SENIOR INDUSTRIES, INC.

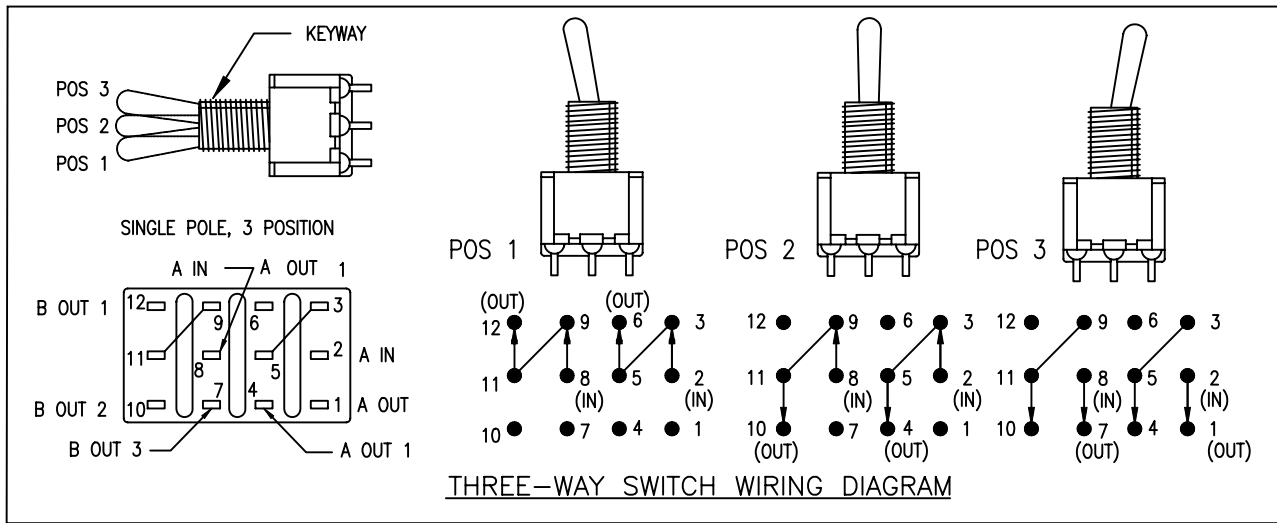
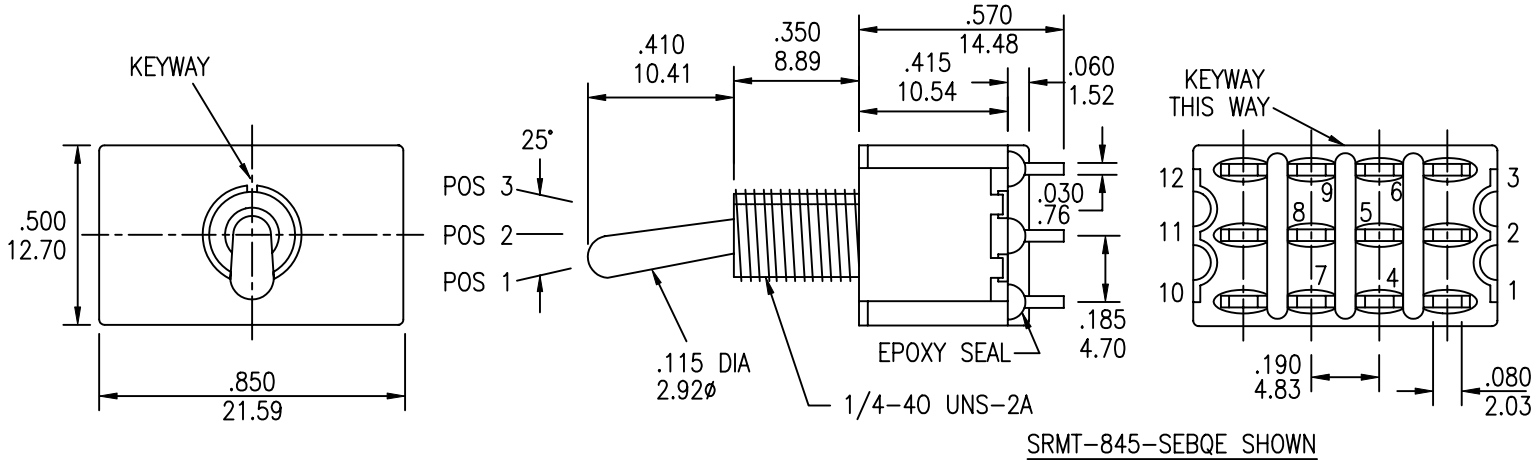

MODEL NO.	SWITCHING POSITION		
845	ON	ON	ON
847	MOM	ON	MOM
849	ON	ON	MOM
CONN. TERMS	2-3, 5-6 8-9, 11-12	2-3, 5-4 8-9, 11-10	2-1, 5-4 8-7, 11-10

NON-SHORTING TYPE

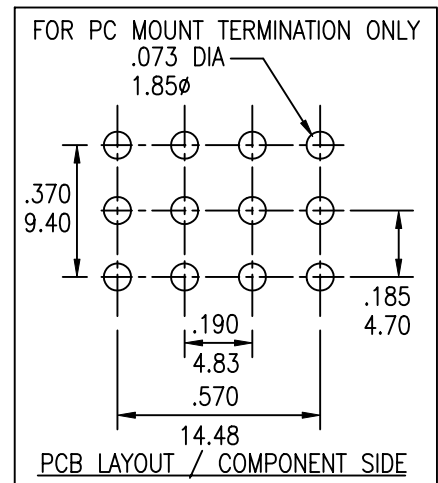

DESIGNED:	SYMBOL	DATE	DESCRIPTION OF REVISIONS	DRAWN	APPD.
		03.05.01	NEW	RB	JF
DRAWN: RB		03/05/01	09.29.04	GAT	TF
CHECKED: GAT		03/18/08	12.14.05	GAT	JF
APPROVED: JF		03/18/08	03.18.08	GAT	JF

3RD ANGLE		UNIT: IN/mm	SCALE: 2:1	REV. D
-----------	--	-------------	------------	--------



TOLERANCE:	PART NO: SRMT-84X-XXXXX
TO 1 DECIMAL PLACE: ±.2	TITLE: TOGGLE SWITCH
TO 2 DECIMAL PLACES: ±.10	
AS ANGLES: ±1/2°	
SHEET:	1 OF 6

1

2

3

4

COMPONENT
SPECIFICATIONUSE OR REPRODUCTION OF THIS DRAWING FOR THE PURPOSE OF MANUFACTURING THIS
ARTICLE OR ANY ARTICLES SHOWN FOR ANY PURPOSE IS STRICTLY PROHIBITED WITHOUT
WRITTEN PERMISSION FROM SENIOR INDUSTRIES, INC.SPECIFICATIONSELECTRICAL

CONTACT RATING:

SILVER: 5A @ 120 VAC OR 28 VDC, 2A @ 250 VAC

GOLD: 0.4 VA MAX. @ 20 V MAX. (AC OR DC)

CONTACT RESISTANCE: 10 MILLIOHMS MAX.

INSULATION RESISTANCE: 1,000 MEGOHMS MIN. AT 500 VDC

DIELECTRIC STRENGTH: 1,000 VRMS

MECHANICAL

LIFE: 40,000 CYCLES

ENVIRONMENTAL

OPERATING TEMPERATURE: -30°C TO +85°C

MATERIAL

CASE: DAP, UL 94V-0

HOUSING: STAINLESS STEEL

ACTUATOR: BRASS, CHROME PLATED

BUSHING: BRASS, NICKEL PLATED

SUPPORT: BRASS, TIN PLATED

CONTACT/TERMINALS: COPPER ALLOY, SILVER OR GOLD PLATED

REGULATORY

UL AND CANADA RECOGNIZED COMPONENT. UL/CUL FILE NO. E173084.

PART NUMBER BUILDER:

SERIES	MODEL NO.	ACTUATOR	BUSHING	TERMINATION	CONTACT PLATING	SEAL
SRMT -		-				
	845	S (STD)	BLANK (Z/Z1 ONLY)		Q (SILVER)	BLANK
	847	T	E (STD - THD)		R (GOLD)	E (EPOXY)
	849	X (LONG)	E1 (STD - THD) (U ONLY)			
		W (LONG)	E2 (STD - THD) (U ONLY)			
		V (LONG)	M (STD - NON-THD)			
		U (FLATTED)	M1 (STD - NON-THD)(U ONLY)			
		Z (LARGE TOGGLE)	M2 (STD - NON-THD)(U ONLY)			
		Z1 (LARGE)	F (THD)			
		Y (PLASTIC)	N (NON-THD)			
		LL1 (LOCKING LEVER)	G (HIGH TORQUE)			
			H (HIGH TORQUE)			
			J (LONG)			
			K (METRIC)			
			L (SPLASH-PROOF)			
			B (SOLDER LUG)			
			C (PC MOUNT)			
			D (QUICK CONNECT)			
			D1 (WIRE WRAP - .736)			
			D2 (WIRE WRAP - .953)			
			D3 (WIRE WRAP - .415)			
			D4 (WIRE WRAP - 1.062)			

DESIGNED:			SYM.	DATE	DESCRIPTION OF REVISIONS	DRAWN	APPD.
				03.05.01	NEW	RB	JF
DRAWN:	RB	03/05/01		09.29.04	Corr dim .450 w/.484. See Page 3	GAT	TF
CHECKED:	GAT	03/18/08		12.14.05	New Index. 3-way wiring diagram schematic & positions corrected	GAT	JF
APPROVED:	JF	03/18/08		03.18.08	Added part's 3rd view, rem'd regul., updated PN builder	GAT	JF

3RD ANGLE

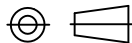

UNIT:

IN/mm

SCALE:

REV.

D

**SENIOR
INDUSTRIES, INC.**

TOLERANCE:

TO 1 DECIMAL PLACE:

TO 2 DECIMAL PLACES:

AS ANGLES:

SHEET:

PART NO:

SRMT-84X-XXXXX

TITLE:

TOGGLE SWITCH

2 OF 6

1 2 3 4

COMPONENT SPECIFICATION

USE OR REPRODUCTION OF THIS DRAWING FOR THE PURPOSE OF MANUFACTURING THIS ARTICLE OR ANY ARTICLES SHOWN FOR ANY PURPOSE IS STRICTLY PROHIBITED WITHOUT WRITTEN PERMISSION FROM SENIOR INDUSTRIES, INC.

A

ACTUATOR OPTIONS

S (STD)

T

X (LONG)

V (LONG)

W (LONG)

U (FLATTED)

Z (LARGE TOGGLE)

Z1

Y (PLASTIC)

LL1 (LOCKING LEVER)

NOTE: OPTIONAL TOGGLE CAP AVAILABLE.

STD FOR S OPTION

STD FOR T OPTION

DESIGNED:			SYM.	DATE	DESCRIPTION OF REVISIONS	DRAWN	APPD.
			▲	03.05.01	NEW	RB	JF
DRAWN:	RB	03/05/01	▲	09.29.04	Corr dim .450 w/.484. See Page 3	GAT	TF
CHECKED:	GAT	03/18/08	▲	12.14.05	New Index. 3-way wiring diagram schematic & positions corrected	GAT	JF
APPROVED:	JF	03/18/08	▲	03.18.08	Added part's 3rd view, rem'd regul., updated PN builder	GAT	JF

3RD ANGLE

UNIT:

IN/mm

SCALE:

REV.

D

SENIOR INDUSTRIES, INC.

TOLERANCE:

TO 1 DECIMAL PLACE:	±.2
TO 2 DECIMAL PLACES:	±.10
AS ANGLES:	±1/2°

PART NO:

SRMT-84X-XXXXX

TITLE:

TOGGLE SWITCH

SHEET:

3 OF 6

E

1

2

3

4

COMPONENT
SPECIFICATIONUSE OR REPRODUCTION OF THIS DRAWING FOR THE PURPOSE OF MANUFACTURING THIS
ARTICLE OR ANY ARTICLES SHOWN FOR ANY PURPOSE IS STRICTLY PROHIBITED WITHOUT
WRITTEN PERMISSION FROM SENIOR INDUSTRIES, INC.

A

BUSHING OPTIONS

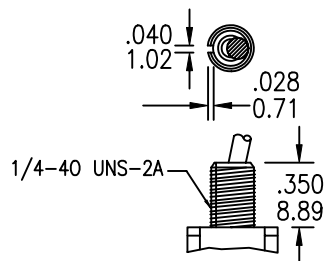
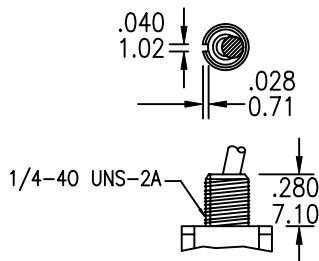
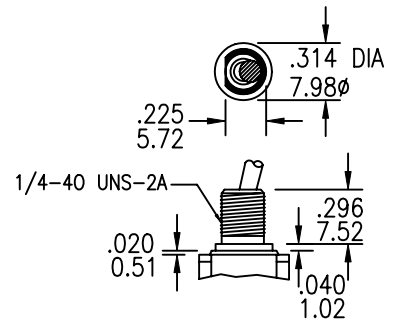
E (STD THD)
M (STD NON-THD)F (THD)
N (NON-THD)

G (HIGH TORQUE)

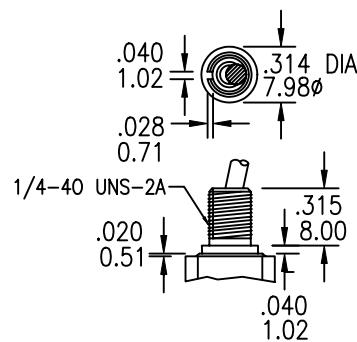

H (HIGH TORQUE)

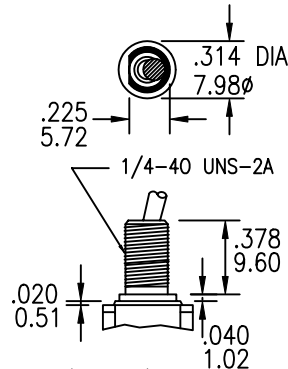

J (LONG)

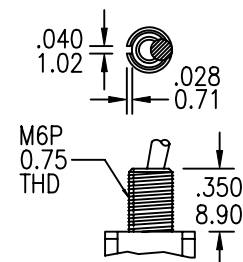

K (METRIC)

C

D

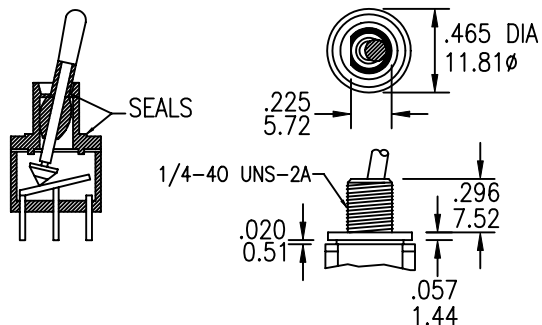

L (SPLASH-PROOF)

USE WITH 'U' (FLATTED) ACTUATOR ONLY

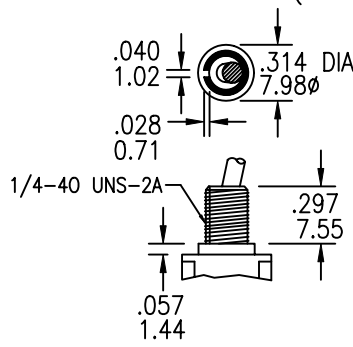
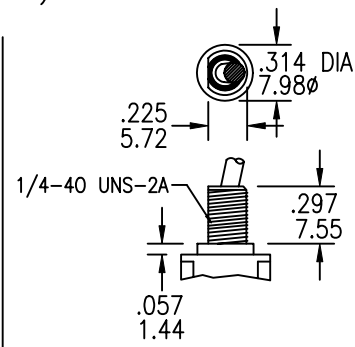
E1 (STD THD)
M1 (STD NON-THD)E2 (STD THD)
M2 (STD NON-THD)

E

DESIGNED:			SYM.	DATE	DESCRIPTION OF REVISIONS	DRAWN	APPD.
			▲	03.05.01	NEW	RB	JF
DRAWN:	RB	03/05/01	▲	09.29.04	Corr dim .450 w/.484. See Page 3	GAT	TF
CHECKED:	GAT	03/18/08	▲	12.14.05	New Index. 3-way wiring diagram schematic & positions corrected	GAT	JF
APPROVED:	JF	03/18/08	▲	03.18.08	Added part's 3rd view, rem'd regul., updated PN builder	GAT	JF

3RD ANGLE

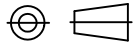

UNIT:

IN/mm

SCALE:

REV.

D

**SENIOR
INDUSTRIES, INC.**

TOLERANCE:

TO 1 DECIMAL PLACE:	±.2
TO 2 DECIMAL PLACES:	±.10
AS ANGLES:	±1/2°

SHEET:

PART NO:

SRMT-84X-XXXXX

TITLE:

TOGGLE SWITCH

4 OF 6

COMPONENT SPECIFICATION

USE OR REPRODUCTION OF THIS DRAWING FOR THE PURPOSE OF MANUFACTURING THIS ARTICLE OR ANY ARTICLES SHOWN FOR ANY PURPOSE IS STRICTLY PROHIBITED WITHOUT WRITTEN PERMISSION FROM SENIOR INDUSTRIES, INC.

TERMINATION OPTIONS

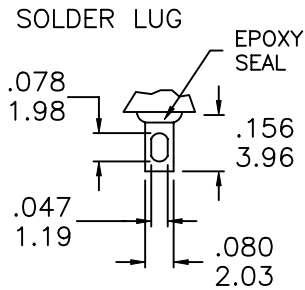

B

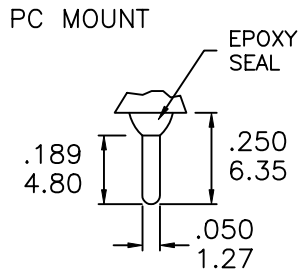

.030 [0.76] THK

C

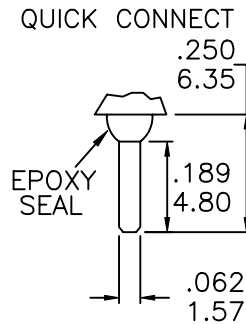

.030 [0.76] THK

D

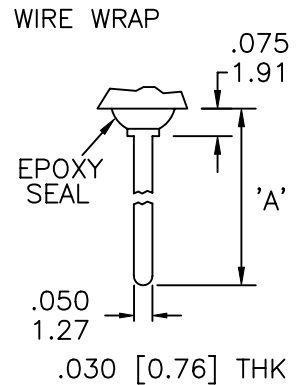

	'A'
D1	.736(18.70)
D2	.953(24.20)
D3	.415(10.54)
D4	1.062(26.97)

DESIGNED:			SYM.	DATE	DESCRIPTION OF REVISIONS	DRAWN	APPD.
			△	03.05.01	NEW	RB	JF
DRAWN:	RB	03/05/01	△	09.29.04	Corr dim .450 w/.484. See Page 3	GAT	TF
CHECKED:	GAT	03/18/08	△	12.14.05	New Index. 3-way wiring diagram schematic & positions corrected	GAT	JF
APPROVED:	JF	03/18/08	△	03.18.08	Added part's 3rd view, rem'd regul., updated PN builder	GAT	JF

3RD ANGLE

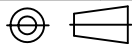

UNIT:

IN/mm

SCALE:

REV.

D



TOLERANCE:

TO 1 DECIMAL PLACE:	±.2
TO 2 DECIMAL PLACES:	±.10
AS ANGLES:	±1/2°

PART NO:

SRMT-84X-XXXXX

TITLE:

TOGGLE SWITCH

SHEET:

5 OF 6

1

2

3

4

COMPONENT SPECIFICATION

USE OR REPRODUCTION OF THIS DRAWING FOR THE PURPOSE OF MANUFACTURING THIS ARTICLE OR ANY ARTICLES SHOWN FOR ANY PURPOSE IS STRICTLY PROHIBITED WITHOUT WRITTEN PERMISSION FROM SENIOR INDUSTRIES, INC.

A

STANDARD NUTS

OPTIONAL NUTS

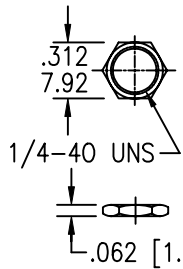

STD FOR E, F, G, H, AND L OPTIONS

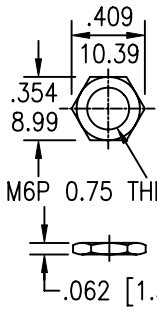

STD FOR K OPTION

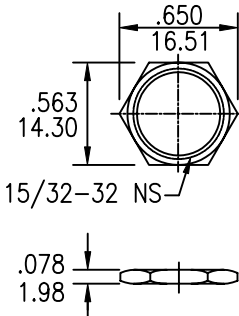

STD FOR Z AND Z1 OPTIONS

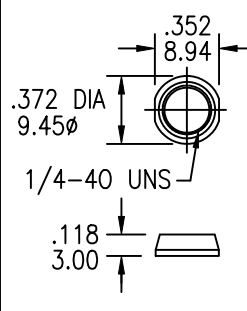

DRESS NUT

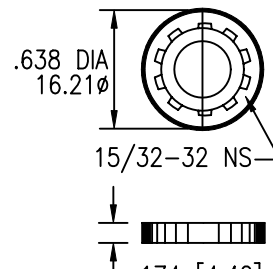

KNURLED

B

LOCK WASHER

LOCKING RING

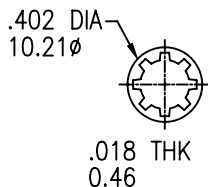

STD

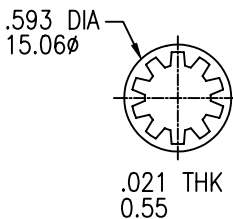

STD FOR Z AND Z1 OPTIONS

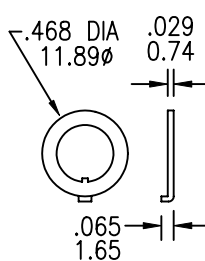

STD

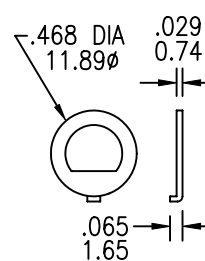

STD FOR G AND J OPTIONS.

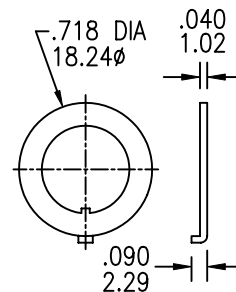

STD FOR Z AND Z1 OPTIONS.

C

PANEL MOUNTING

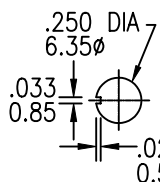

FOR BUSHING E, M, F, N, AND H OPTIONS

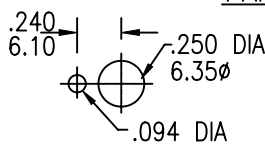

FOR BUSHING G, J, AND L OPTIONS

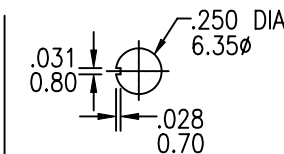
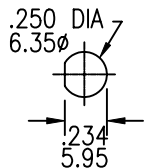

FOR BUSHING K OPTION

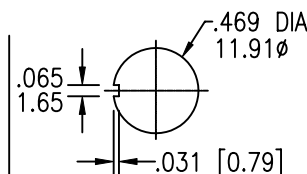

FOR ACTUATOR Z AND Z1 OPTIONS

D

DESIGNED:			SYM.	DATE	DESCRIPTION OF REVISIONS	DRAWN	APPD.
DRAWN:	RB	03/05/01	△	03.05.01	NEW	RB	JF
CHECKED:	GAT	03/18/08	△	09.29.04	Corr dim .450 w/.484. See Page 3	GAT	TF
APPROVED:	JF	03/18/08	△	12.14.05	New Index. 3-way wiring diagram schematic & positions corrected	GAT	JF
			△	03.18.08	Added part's 3rd view, rem'd regul., updated PN builder	GAT	JF

E

3RD ANGLE

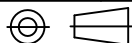

UNIT:

IN/mm

SCALE:

REV.

D



SENIOR INDUSTRIES, INC.

TOLERANCE:

TO 1 DECIMAL PLACE:	±.2
TO 2 DECIMAL PLACES:	±.10
AS ANGLES:	±1/2°

PART NO:

SRMT-84X-XXXXX

TITLE:

TOGGLE SWITCH

SHEET:

6 OF 6