

UNLESS OTHERWISE SPECIFIED, ALL DIMENSIONS ARE IN INCHES [MM].

TO 1 DECIMAL PLACE ±.2
 TO 2 DECIMAL PLACES ±.10
 AS ANGLES ±

ISSUE	DATE
B	09/29/04
C	03/14/08
D	03/20/08

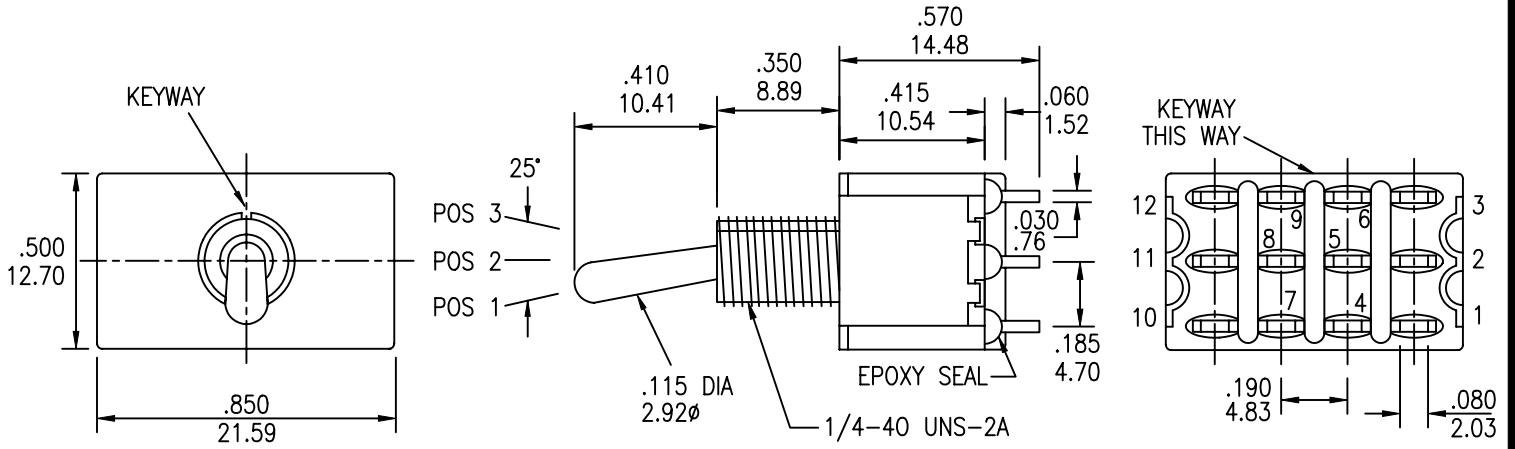

SRMT-8401-SEBQE SHOWN

MODEL NO.	SWITCHING POSITION		
8401	ON	NONE	ON
8403	ON	NONE	MOM
8405	ON	OFF	ON
8407	MOM	OFF	MOM
8409	ON	OFF	MOM
CONN. TERMS	2-3, 5-6 8-9, 11-12	OPEN	2-1, 5-4 8-7, 11-10
SCHEMATIC			

NON-SHORTING TYPE

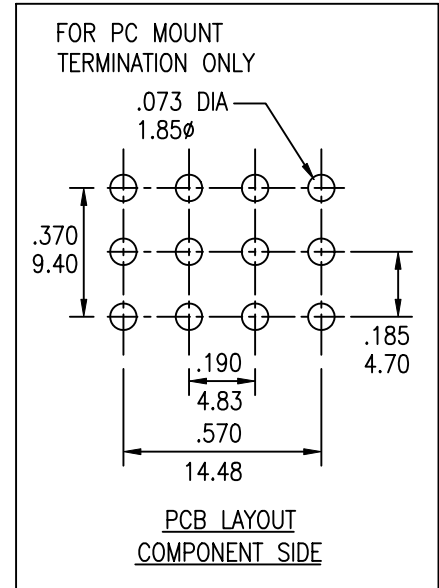

TITLE: TOGGLE SWITCH

PART NO: SRMT-84XX-XXXXX

DATE: 03/05/01

DRAWN: RB

CHKD: GAT

SCALE: 2/1

SHEET: 1 OF 6

UNLESS OTHERWISE SPECIFIED, ALL DIMENSIONS ARE IN INCHES [MM].

TO 1 DECIMAL PLACE ±.2
 TO 2 DECIMAL PLACES ±.10
 AS ANGLES ±

ISSUE	DATE
B	09/29/04
C	03/14/08
D	03/20/08

SPECIFICATIONS

ELECTRICAL

CONTACT RATING:

SILVER: 5A @ 120 VAC OR 28 VDC, 2A @ 250 VAC
 GOLD: 0.4 VA MAX. @ 20 V MAX. (AC OR DC)

CONTACT RESISTANCE: 10 MILLIOHMS MAX.

INSULATION RESISTANCE: 1,000 MEGOHMS MIN. AT 500 VDC

DIELECTRIC STRENGTH: 1,000 VRMS

MECHANICAL

LIFE: 40,000 CYCLES

ENVIRONMENTAL

OPERATING TEMPERATURE: -30°C TO +85°C

MATERIAL

CASE: DAP, UL 94V-0

HOUSING: STAINLESS STEEL

ACTUATOR: BRASS, CHROME PLATED

BUSHING: BRASS, NICKEL PLATED

SUPPORT: BRASS, TIN PLATED

CONTACT/TERMINALS: COPPER ALLOY, SILVER OR GOLD PLATED

REGULATORY

UL AND CANADA RECOGNIZED COMPONENT. UL/CUL FILE NO. E173084.

PART NUMBER BUILDER:

SERIES	MODEL NO.	ACTUATOR	BUSHING	TERMINATION	CONTACT PLATING	SEAL
SRMT	□□□□□	□	□	□	□	□
	8401	S (STD)	BLANK (Z/Z1 ONLY)		Q (SILVER)	BLANK
	8403	T	E (STD - THD)		R (GOLD)	E (EPOXY)
	8405	X (LONG)	E1 (STD - THD) (U ONLY)	B (SOLDER LUG) C (PC MOUNT) D (QUICK CONNECT) D1 (WIRE WRAP - .736) D2 (WIRE WRAP - .953) D3 (WIRE WRAP - .415) D4 (WIRE WRAP - 1.062)		
	8407	V (LONG)	E2 (STD - THD) (U ONLY)			
	8407	W (LONG)	M (STD - NON-THD)			
	8409	U (FLATTED)	M1 (STD - NON-THD)(U ONLY)			
		Z (LARGE TOGGLE)	M2 (STD - NON-THD)(U ONLY)			
		Z1 (LARGE)	F (THD)			
		Y (PLASTIC)	N (NON-THD)			
		LL1 (LOCKING LEVER)	G (HIGH TORQUE)			
			H (HIGH TORQUE)			
			J (LONG)			
			K (METRIC)			
			L (SPLASH-PROOF)			
			L1 (SPLASH-PROOF) (Z/Z1 ONLY)			



TITLE: TOGGLE SWITCH		PART NO: SRMT-84XX-XXXXX			
DATE: 03/05/01	DRAWN: RB	CHKD: GAT	SCALE: N/A	SHEET: 2 OF 6	

UNLESS OTHERWISE SPECIFIED, ALL DIMENSIONS ARE IN INCHES [MM].

TO 1 DECIMAL PLACE ±.2
 TO 2 DECIMAL PLACES ±.10
 AS ANGLES ±

ISSUE	DATE
B	09/29/04
C	03/14/08
D	03/20/08

ACTUATOR OPTIONS

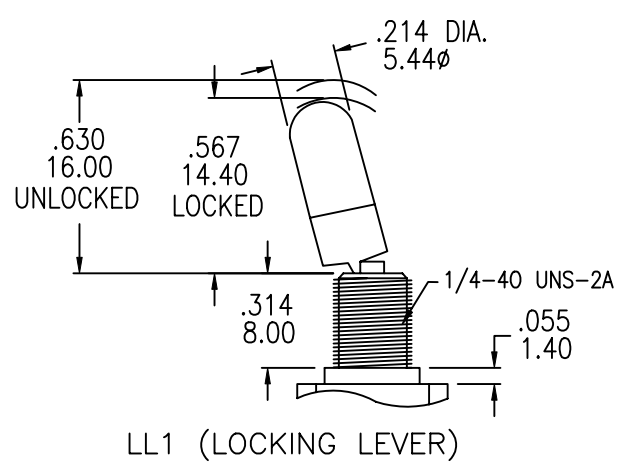
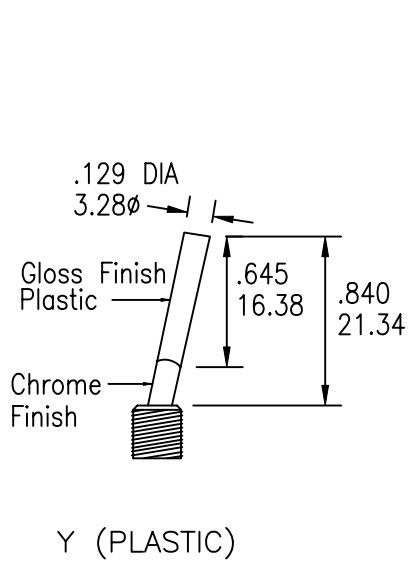
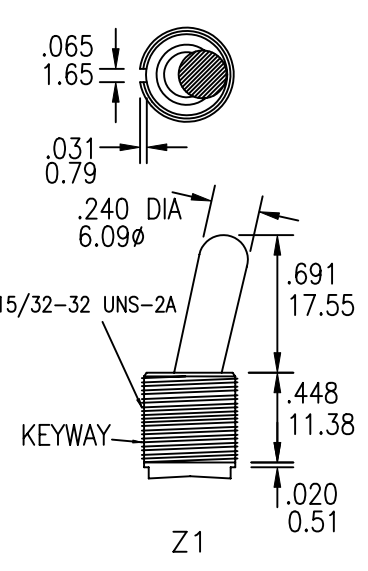
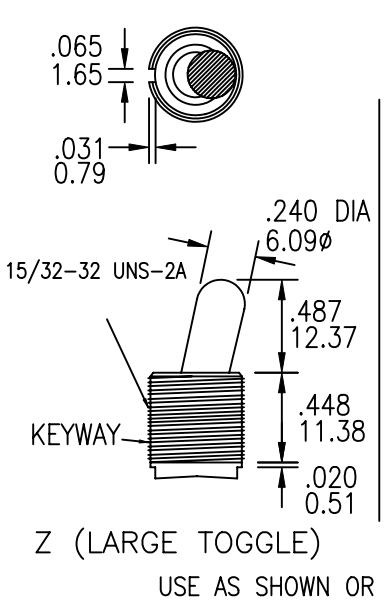
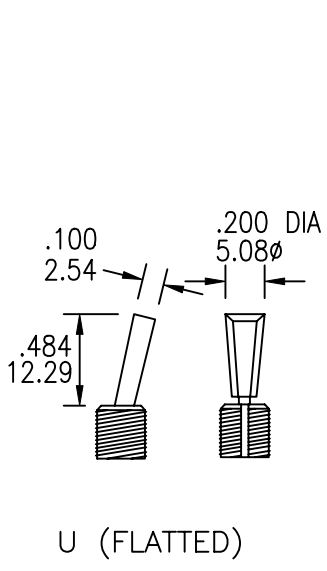
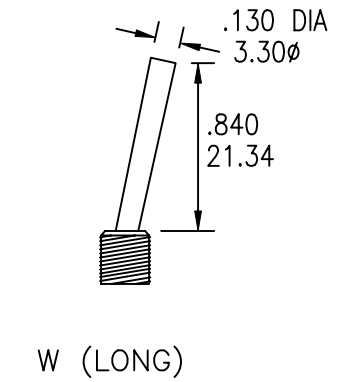
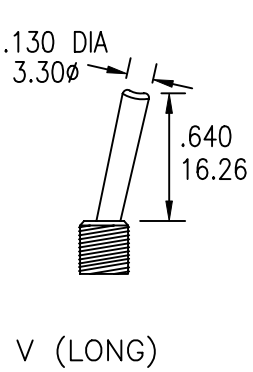
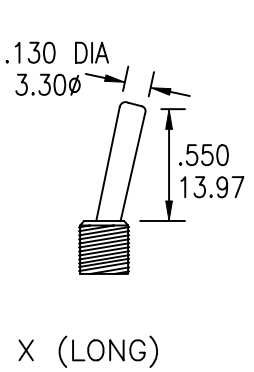
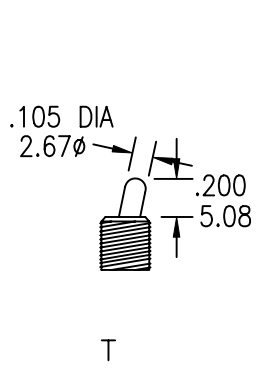
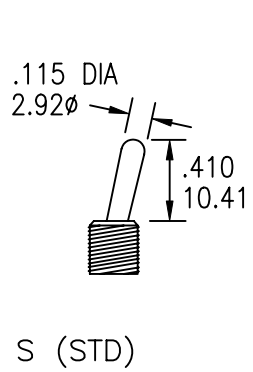

NOTE: OPTIONAL TOGGLE CAP AVAILABLE.

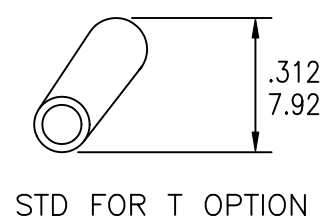
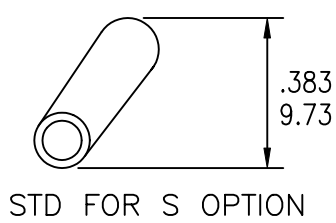

TITLE: TOGGLE SWITCH		PART NO: SRMT-84XX-XXXXX		
DATE: 03/05/01	DRAWN: RB	CHKD: GAT	SCALE: N/A	SHEET: 3 OF 6

UNLESS OTHERWISE SPECIFIED, ALL DIMENSIONS ARE IN INCHES [MM].

TO 1 DECIMAL PLACE ±.2
 TO 2 DECIMAL PLACES ±.10
 AS ANGLES ±

ISSUE	DATE
B	09/29/04
C	03/14/08
D	03/20/08

BUSHING OPTIONS

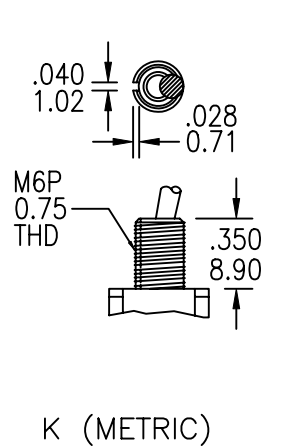
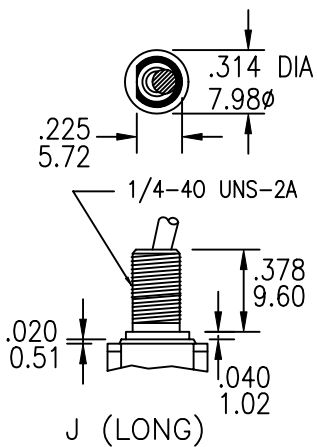
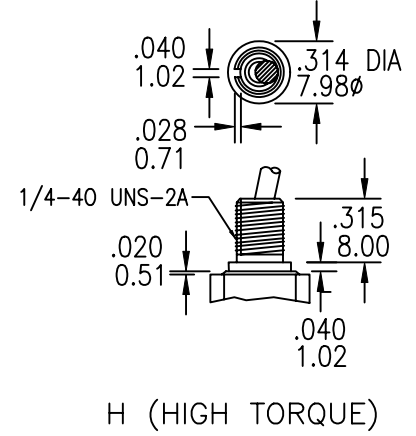
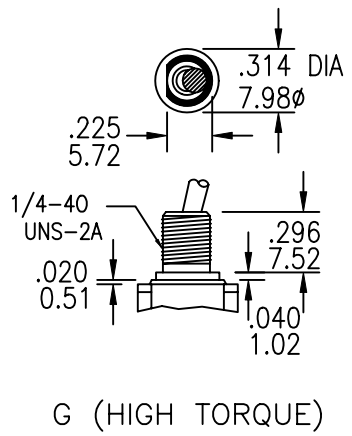
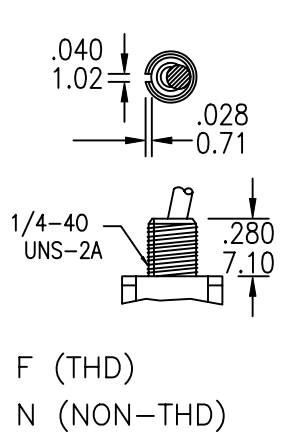
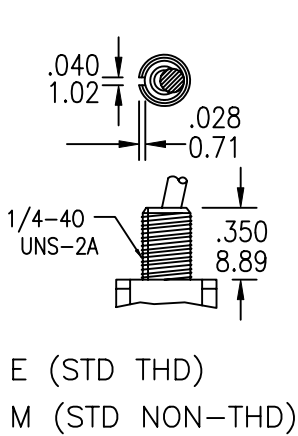

USE WITH 'U' (FLATTED) ACTUATOR ONLY

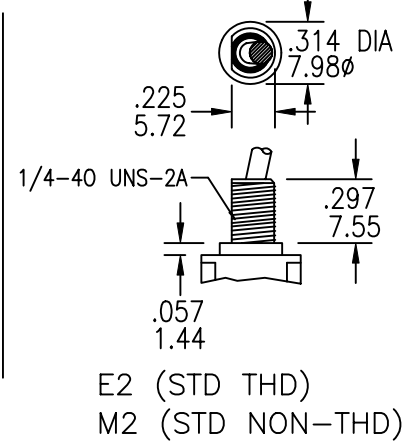
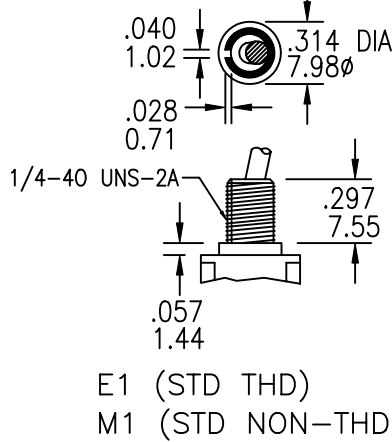

USE WITH 'Z' OR 'Z1' ACTUATOR ONLY

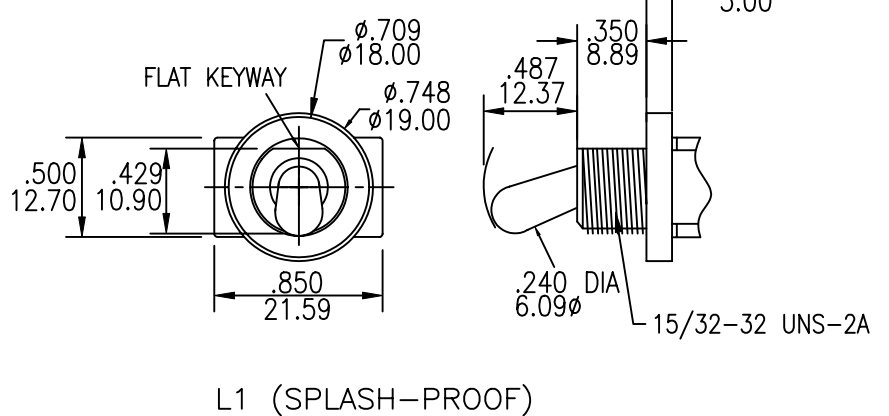
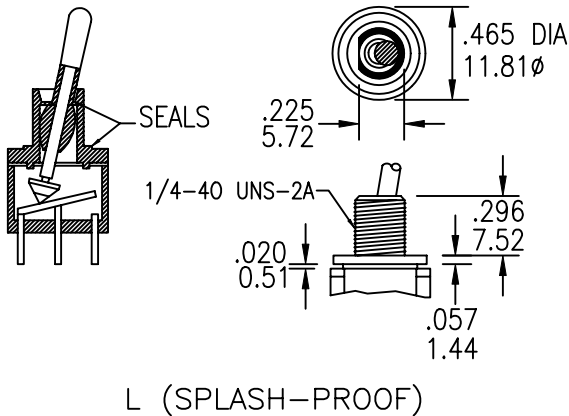

UNLESS OTHERWISE SPECIFIED, ALL DIMENSIONS ARE IN INCHES [MM].

TO 1 DECIMAL PLACE ±.2
 TO 2 DECIMAL PLACES ±.10
 AS ANGLES ±

ISSUE	DATE
B	09/29/04
C	03/14/08
D	03/20/08

TERMINATION OPTIONS

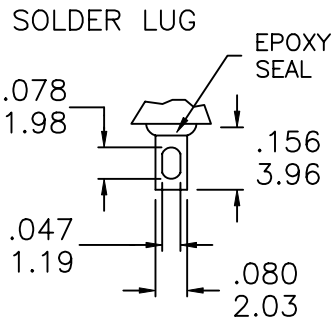

B

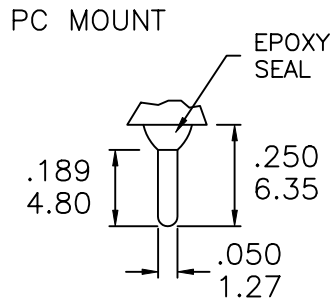

.030 [0.76] THK

C

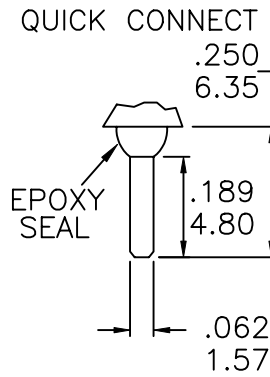

.030 [0.76] THK

D

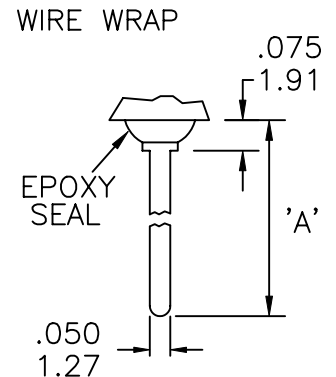

.030 [0.76] THK

	'A'
D1	.736(18.70)
D2	.953(24.20)
D3	.415(10.54)
D4	1.062(26.97)

UNLESS OTHERWISE SPECIFIED, ALL DIMENSIONS ARE IN INCHES [MM].

TO 1 DECIMAL PLACE ±.2
 TO 2 DECIMAL PLACES ±.10
 AS ANGLES ±

ISSUE	DATE
C	03/17/08
D	03/20/08

STANDARD NUTS

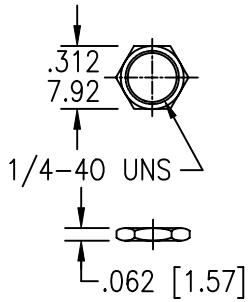

STD FOR E, F, G,
H, AND L OPTIONS

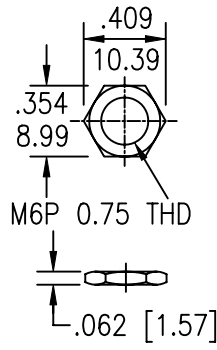

STD FOR K OPTION

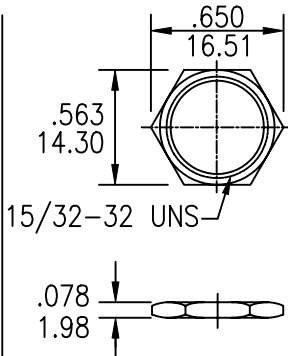

STD FOR Z
AND Z1 OPTIONS

OPTIONAL NUTS

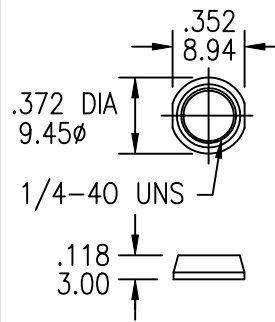

DRESS NUT

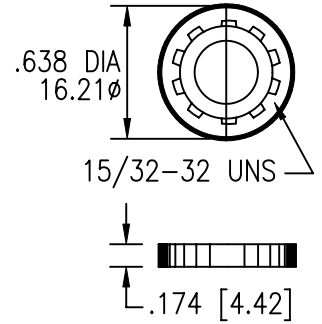

KNURLED

LOCK WASHER

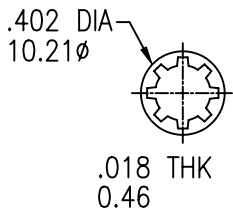

STD FOR E AND F

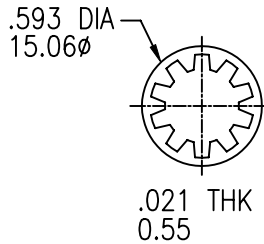

STD FOR Z AND Z1 OPTIONS

LOCKING RING

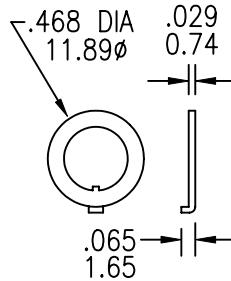

STD

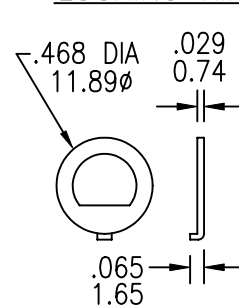

STD FOR G
AND J OPTIONS.

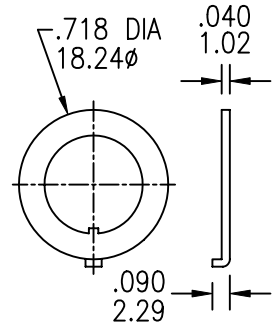

STD FOR Z
AND Z1 OPTIONS.

PANEL MOUNTING

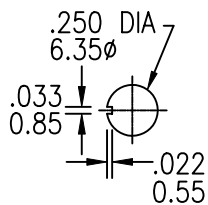

FOR BUSHING E, M, F, N, AND H OPTIONS

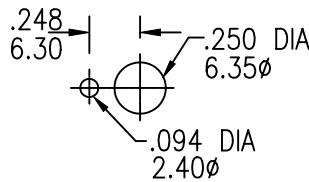
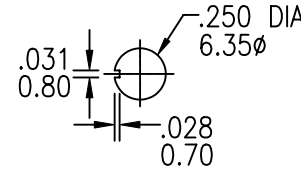
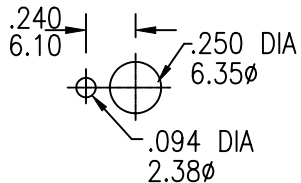

FOR BUSHING K OPTION

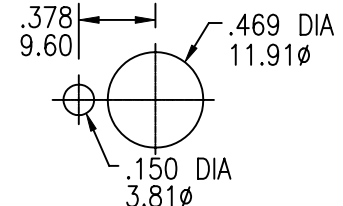
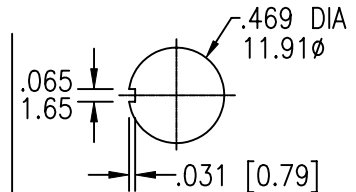

FOR ACTUATOR Z AND Z1 OPTIONS

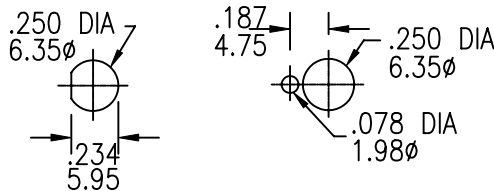

FOR BUSHING G, J, AND L OPTIONS



TITLE: TOGGLE SWITCH

PART NO: SRMT-84XX-XXXXX

DATE: 03/05/01

DRAWN: RB

CHKD: GAT

SCALE: N/A

SHEET: 6 OF 6