

UNLESS OTHERWISE SPECIFIED, ALL DIMENSIONS ARE IN INCHES [MM].

TO 1 DECIMAL PLACE ±.2
 TO 2 DECIMAL PLACES ±.10
 AS ANGLES ±

ISSUE	DATE
A	03/15/01
B	03/27/01

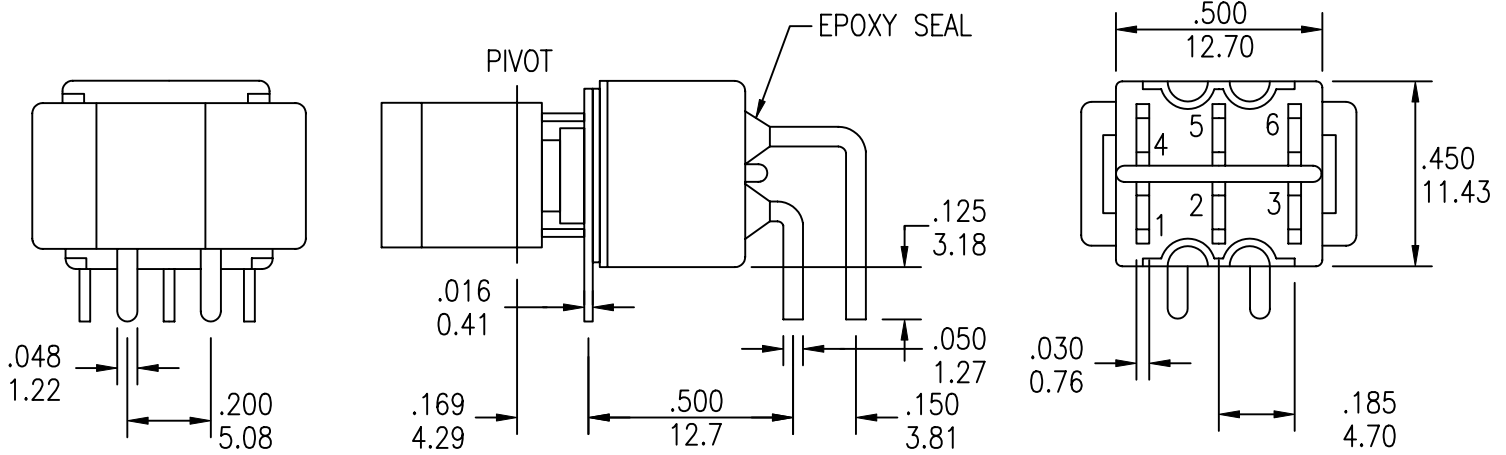

MODEL NO.	SWITCHING POSITION		
8017P	ON	NONE	ON
8017PA	ON	NONE	MOM
8018P	ON	OFF	ON
8018PA	MOM	OFF	MOM
8018PB	ON	OFF	MOM
CONN. TERMS	2-3 5-6	OPEN	2-1 5-4
SCHEMATIC	<p>DPDT 1 2 3 4 5 6 Comm. Comm.</p>		

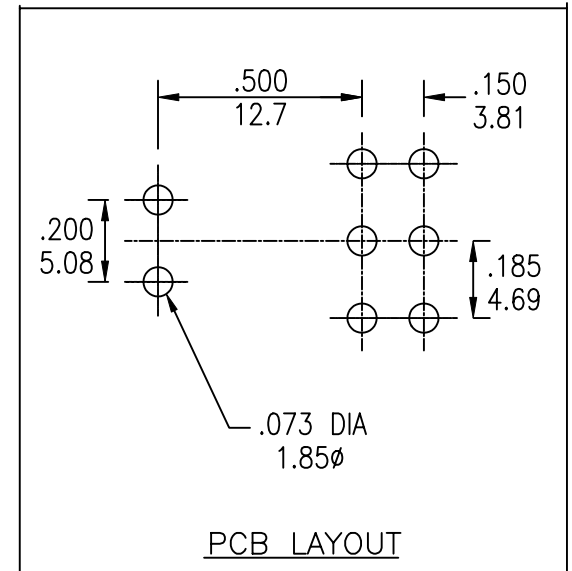

UNLESS OTHERWISE SPECIFIED, ALL DIMENSIONS ARE IN INCHES [MM].

TO 1 DECIMAL PLACE ±.2
 TO 2 DECIMAL PLACES ±.10
 AS ANGLES ±

ISSUE	DATE
A	03/15/01
B	03/27/01

SPECIFICATIONS

ELECTRICAL

CONTACT RATING:

SILVER: 5A @ 120 VAC OR 28 VDC, 2A @ 250 VAC
 GOLD: 0.4 VA MAX. @ 20 V MAX. (AC OR DC)

CONTACT RESISTANCE: 10 MILLIOHMS MAX.

INSULATION RESISTANCE: 1,000 MEGOHMS MIN. AT 500 VDC

DIELECTRIC STRENGTH: 1,000 VRMS

MECHANICAL

LIFE: 50,000 CYCLES

ENVIRONMENTAL

OPERATING TEMPERATURE: -30°C TO +85°C

MATERIAL

CASE: DAP, UL 94V-0

HOUSING: STAINLESS STEEL

ACTUATOR: NYLON

BUSHING: BRASS, NICKEL PLATED

SUPPORT: BRASS, TIN PLATED

CONTACT/TERMINALS: COPPER ALLOY, SILVER OR GOLD PLATED

REGULATORY

UL AND CANADA RECOGNIZED COMPONENT. UL/CUL FILE NO. E173084.

SERIES	MODEL NO.	ACTUATOR	ACTUATOR COLOR	TERMINATION	CONTACT PLATING	SEAL
SRPR	□□□□□	□	□	□	□	□
	8017P	R11 (ROCKER)	1 - BLUE	C (PC MOUNT)	Q (SILVER)	BLANK
	8017PA	R12 (ROCKER W/BEZEL)	2 - RED		R (GOLD)	E (EPOXY)
	8018P	R15 (LARGE ROCKER)	3 - BLACK			
	8018PA	P13 (PADDLE)	4 - BROWN			
	8018PB	P14 (PADDLE W/BEZEL)	5 - GREEN			
		P16 (LARGE PADDLE)	6 - WHITE			
			7 - GRAY			
			8 - ORANGE			
			9 - YELLOW			
			0 - VIOLET			



TITLE: SRPR 8017P/8018P ROCKER/PADDLE SWITCHES			PART NO: SEE CHART		
DATE: 03/05/01	DRAWN: RB	CHKD:	SCALE: N/A	SHEET: 2 OF 4	

UNLESS OTHERWISE SPECIFIED, ALL DIMENSIONS ARE IN INCHES [MM].

TO 1 DECIMAL PLACE ±.2
 TO 2 DECIMAL PLACES ±.10
 AS ANGLES ±

ISSUE	DATE
A	03/15/01
B	03/27/01

ACTUATOR OPTIONS

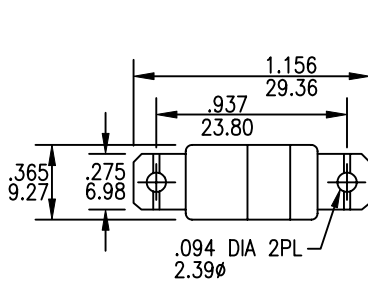

R11

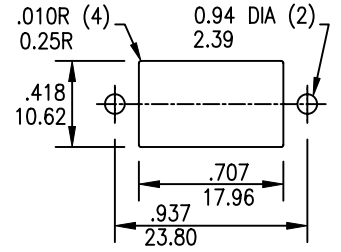
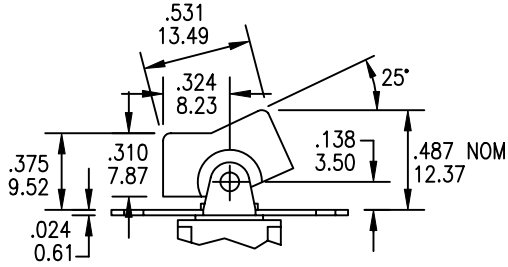

PANEL MOUNTING

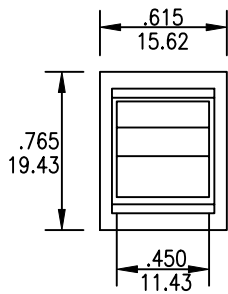

R12

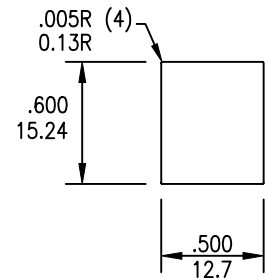
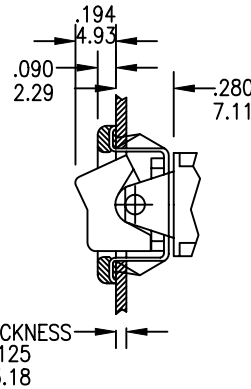

PANEL MOUNTING

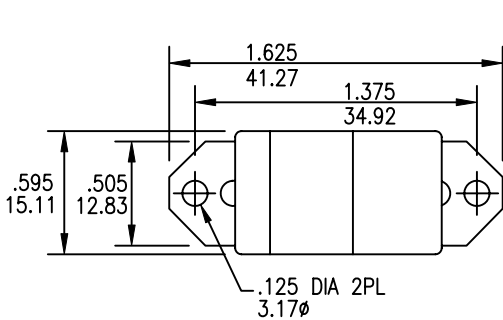

R15

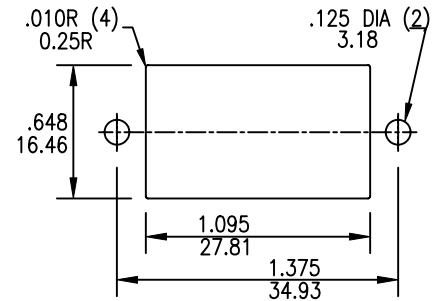
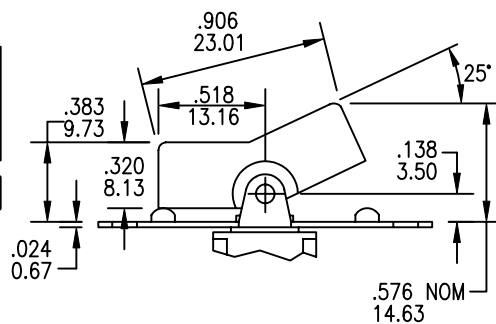

PANEL MOUNTING

UNLESS OTHERWISE SPECIFIED, ALL DIMENSIONS ARE IN INCHES [MM].

TO 1 DECIMAL PLACE ±.2
 TO 2 DECIMAL PLACES ±.10
 AS ANGLES ±

ISSUE	DATE
A	03/15/01
B	03/27/01

ACTUATOR OPTIONS

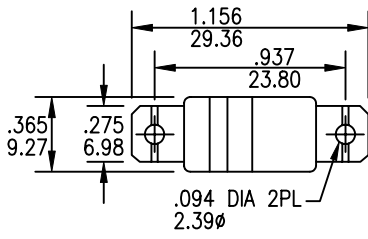

P13

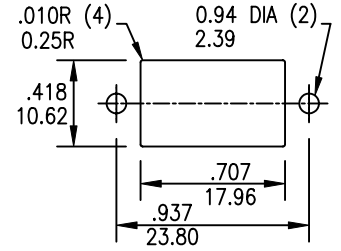
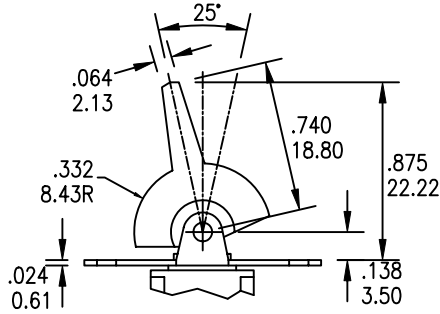

PANEL MOUNTING

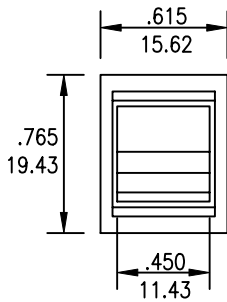

P14

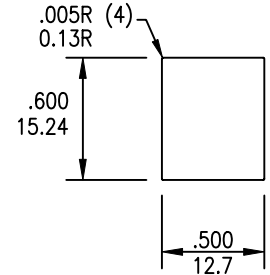
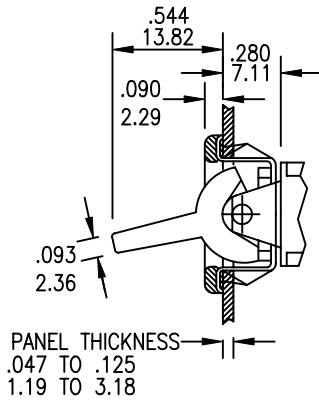

PANEL MOUNTING

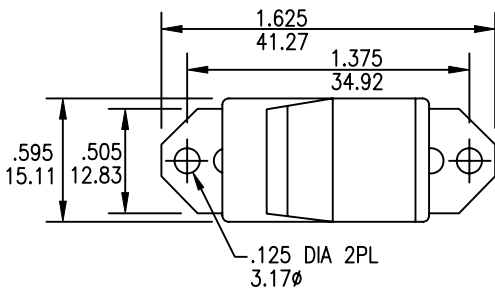

P16

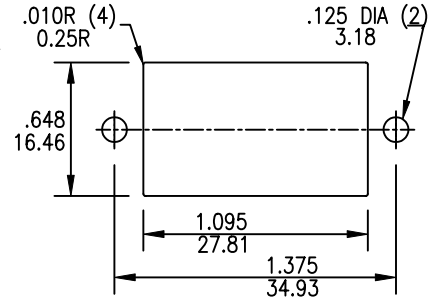
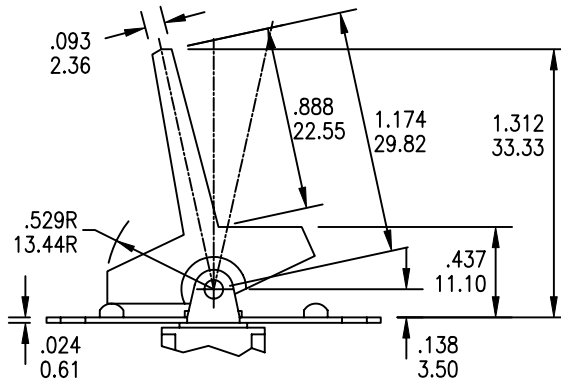

PANEL MOUNTING

TERMINATION

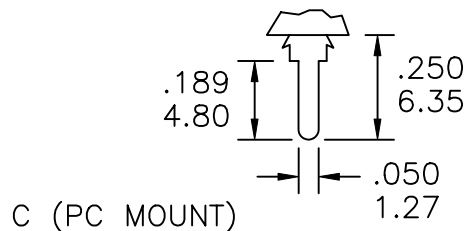

C (PC MOUNT)