

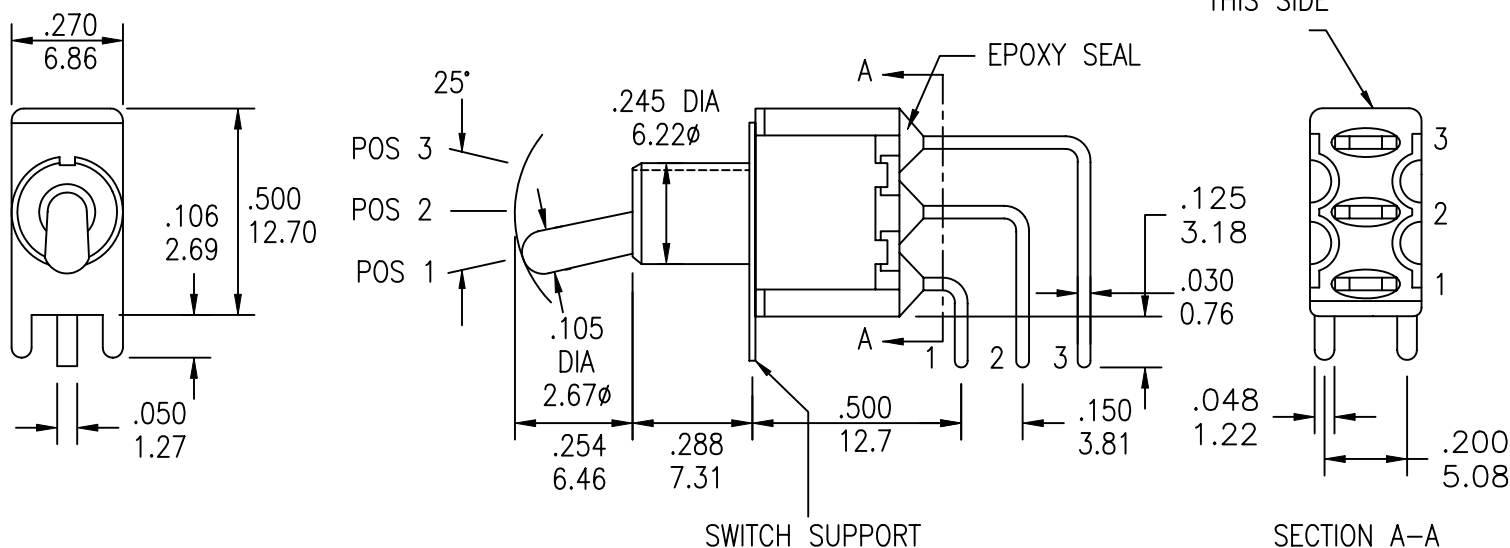



UNLESS OTHERWISE SPECIFIED, ALL DIMENSIONS ARE IN INCHES [MM].

TO 1 DECIMAL PLACE ±.2  
 TO 2 DECIMAL PLACES ±.10  
 AS ANGLES ±

ISSUE	DATE
E	01/16/06
F	05/03/07

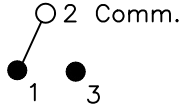

MODEL NO.	SWITCHING POSITION		
			
8019L	ON	NONE	ON
8019LA	ON	NONE	MOM
8020L	ON	OFF	ON
8020LA	MOM	OFF	MOM
8020LB	ON	OFF	MOM
CONN. TERMS	2-3	OPEN	2-1
SCHMATIC			

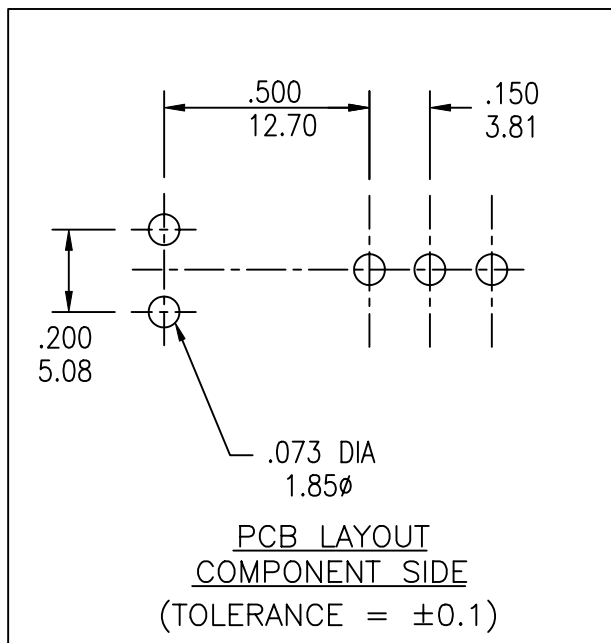

UNLESS OTHERWISE SPECIFIED, ALL DIMENSIONS ARE IN INCHES [MM].  
 TO 1 DECIMAL PLACE ±.2  
 TO 2 DECIMAL PLACES ±.10  
 AS ANGLES ±

ISSUE	DATE
E	01/16/06
F	05/03/07

SPECIFICATIONS

ELECTRICAL

CONTACT RATING:  
 SILVER: 5A @ 120 VAC OR 28 VDC, 2A @ 250 VAC  
 GOLD: 0.4 VA MAX. @ 20 V MAX. (AC OR DC)

CONTACT RESISTANCE: 10 MILLIOHMS MAX.  
 INSULATION RESISTANCE: 1,000 MEGOHMS MIN. AT 500 VDC  
 DIELECTRIC STRENGTH: 1,000 VRMS

MECHANICAL

LIFE: 40,000 CYCLES

ENVIRONMENTAL

OPERATING TEMPERATURE: -30°C TO +85°C

MATERIAL

CASE: DAP, UL 94V-0  
 HOUSING: STAINLESS STEEL  
 ACTUATOR: BRASS, CHROME PLATED  
 BUSHING: BRASS, NICKEL PLATED  
 SUPPORT: BRASS, TIN PLATED  
 CONTACT/TERMINALS: COPPER ALLOY, SILVER OR GOLD PLATED

REGULATORY

UL AND CANADA RECOGNIZED COMPONENT. UL/CUL FILE NO. E173084.

PART NUMBER BUILDER

SERIES	MODEL NO.	ACTUATOR	BUSHING	TERMINATION	CONTACT PLATING	SEAL
SRPT	- □□□□□	- □	□	□	□	□
	8019L	S (STD)	BLANK (Z/Z1 ONLY)		Q (SILVER)	BLANK
	8019LA	T	E (STD - THD)		R (GOLD)	E (EPOXY)
	8020L	X (LONG)	M (STD - NON-THD)			
	8020LA	W (LONG)	F (THD)		C (PC MOUNT)	
	8020LB	V (LONG)	N (NON-THD)			
		U (FLATTED)	G (HIGH TORQUE)			
		Z (LARGE TOGGLE)	H (HIGH TORQUE)			
		Z1 (LARGE)	J (LONG)			
		Y (PLASTIC)	K (METRIC)			
			L (SPLASH-PROOF)			



TITLE: SRPT 8019L/8020L TOGGLE SWITCHES			PART NO: SEE CHART		
DATE: 03/05/01	DRAWN: RB	CHKD:	SCALE: N/A	SHEET: 2 OF 5	

UNLESS OTHERWISE SPECIFIED, ALL DIMENSIONS ARE IN INCHES [MM].

TO 1 DECIMAL PLACE ±.2  
 TO 2 DECIMAL PLACES ±.10  
 AS ANGLES ±

ISSUE	DATE
E	01/16/06
F	05/03/07

ACTUATOR OPTIONS

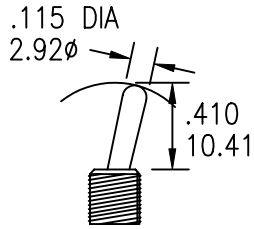

S (STD)

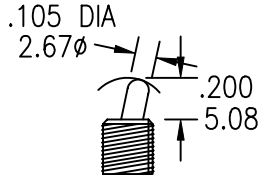

T

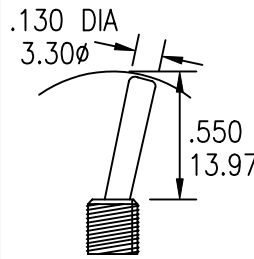

X (LONG)

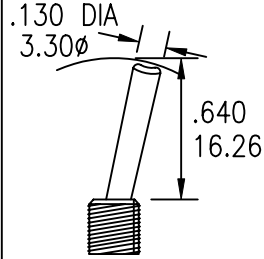

W (LONG)

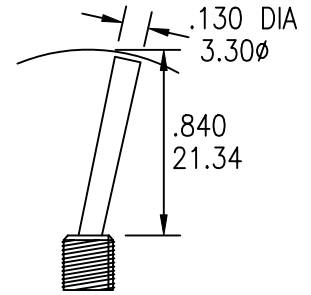

V (LONG)

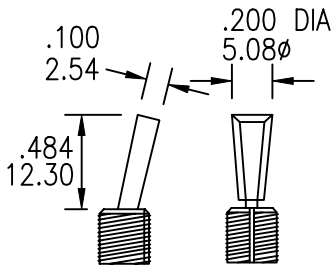

U (FLATTED)

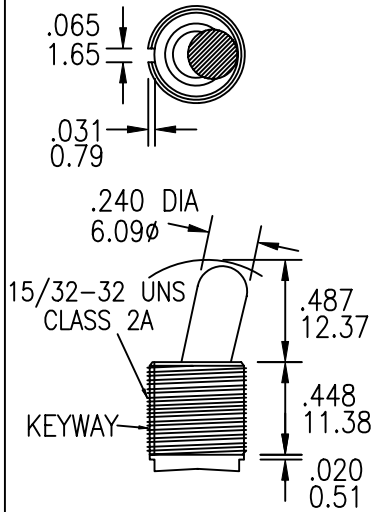

Z (LARGE TOGGLE)

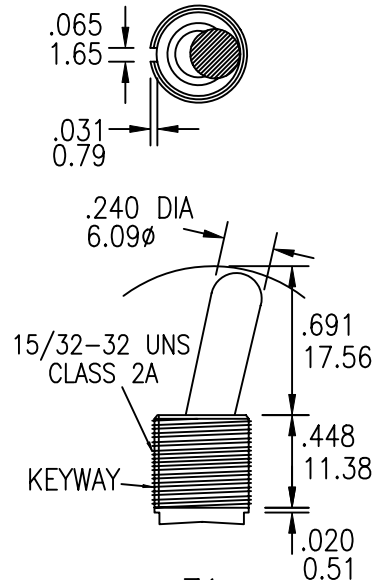

Z1

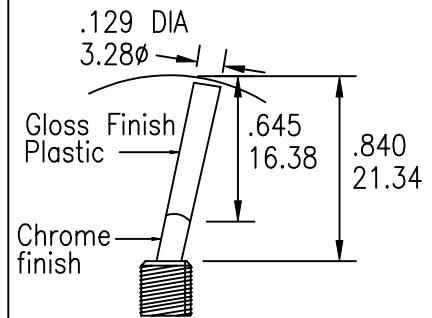

Y (PLASTIC)

NOTE: OPTIONAL TOGGLE CAP AVAILABLE.

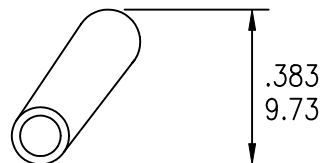

STD FOR S OPTION

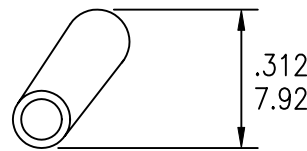

STD FOR T OPTION

UNLESS OTHERWISE SPECIFIED, ALL DIMENSIONS ARE IN INCHES [MM].

TO 1 DECIMAL PLACE ±.2  
 TO 2 DECIMAL PLACES ±.10  
 AS ANGLES ±

ISSUE	DATE
E	01/16/06
F	05/03/07

BUSHING OPTIONS

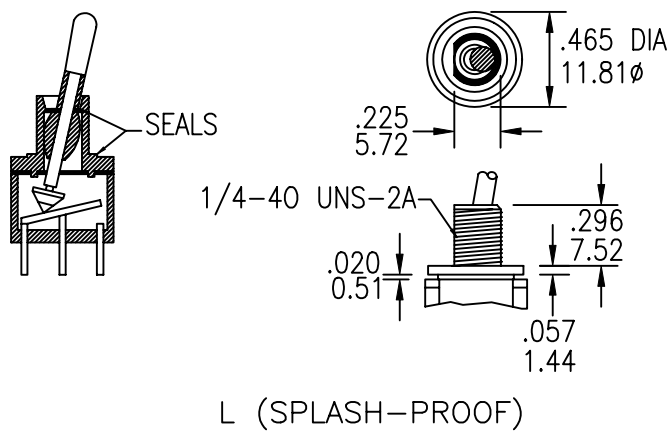
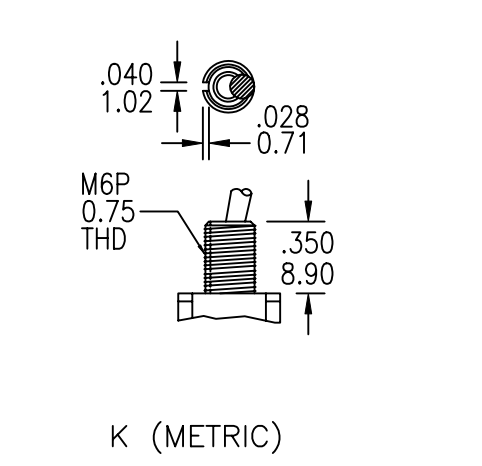
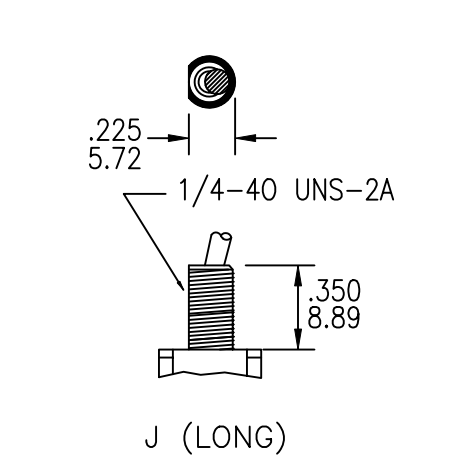
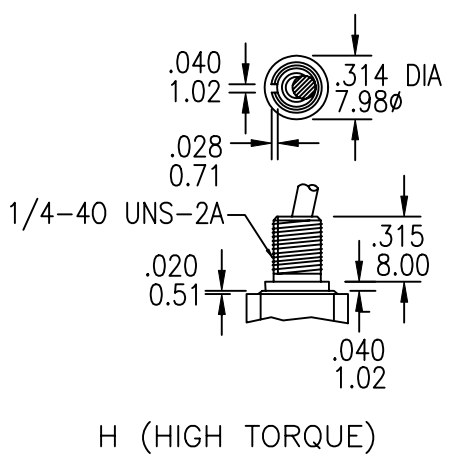
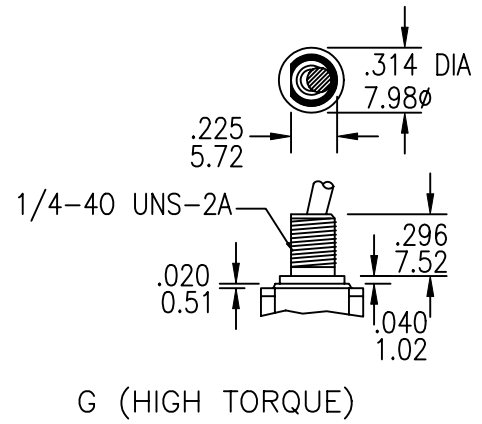
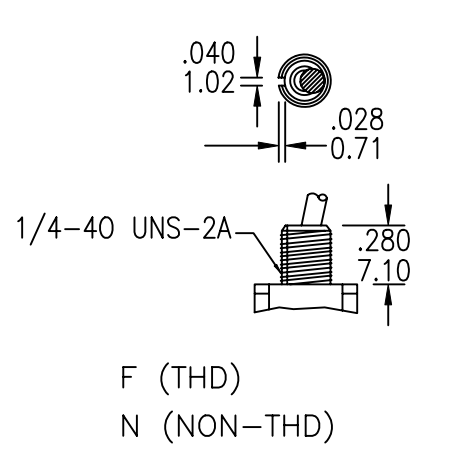
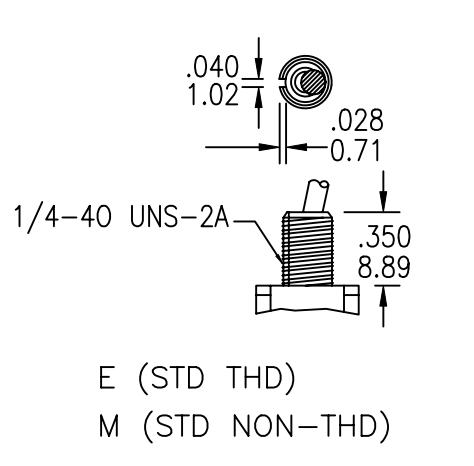

TERMINATION

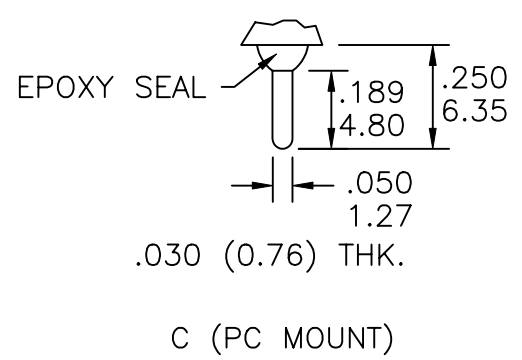

UNLESS OTHERWISE SPECIFIED, ALL DIMENSIONS ARE IN INCHES [MM].

TO 1 DECIMAL PLACE ±.2  
 TO 2 DECIMAL PLACES ±.10  
 AS ANGLES ±

ISSUE	DATE
E	01/16/06
F	05/03/07

STANDARD NUTS

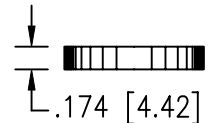
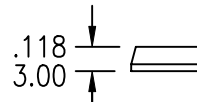
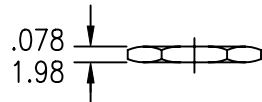
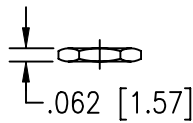
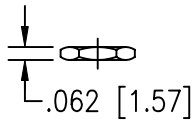
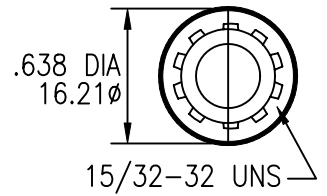
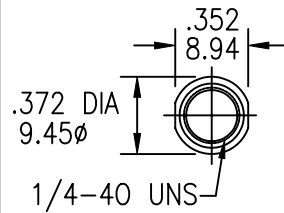
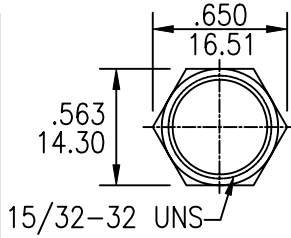
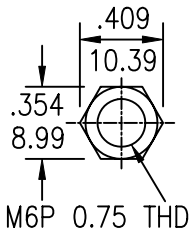
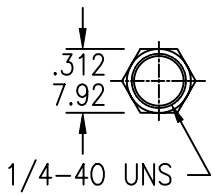

STD FOR E, F, G, H, AND L OPTIONS

STD FOR K OPTION

STD FOR Z AND Z1 OPTIONS

DRESS NUT

KNURLED

LOCK WASHER

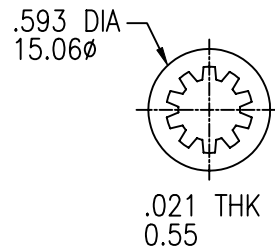
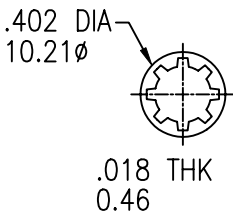

STD

STD FOR Z AND Z1 OPTIONS

LOCKING RING

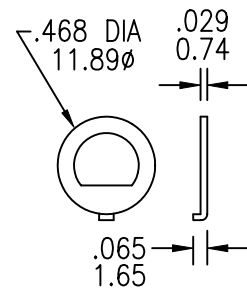
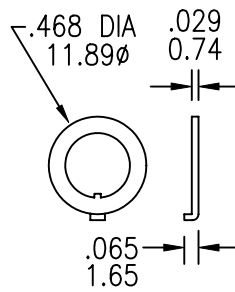

STD

STD FOR G OPTION

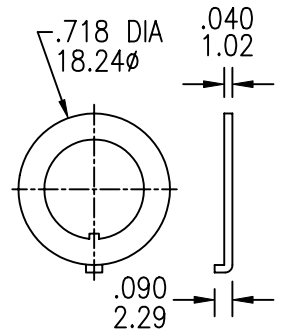

STD FOR Z AND Z1 OPTIONS.

PANEL MOUNTING

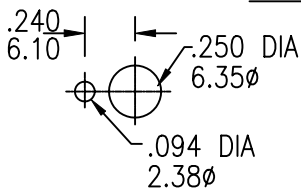
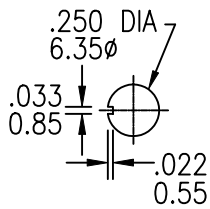

FOR BUSHING E, M, F, N, AND H OPTIONS

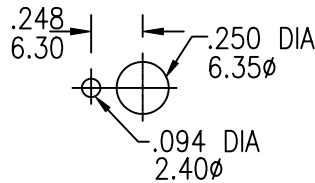
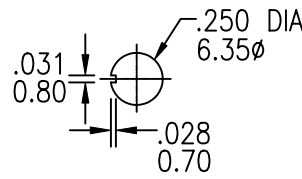

FOR BUSHING K OPTION

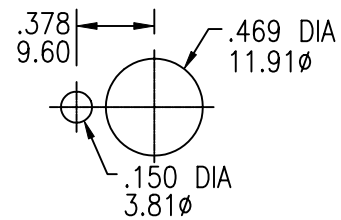
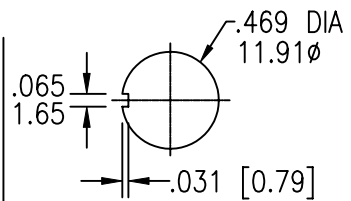

FOR ACTUATOR Z AND Z1 OPTIONS

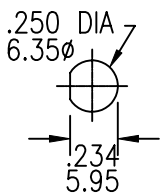

FOR BUSHING G, J, AND L OPTIONS



TITLE: SRPT 8019L/8020L TOGGLE SWITCHES

PART NO: SEE CHART

DATE: 03/05/01

DRAWN: RB

CHKD:

SCALE: N/A

SHEET: 5 OF 5