

UNLESS OTHERWISE SPECIFIED, ALL DIMENSIONS ARE IN INCHES [MM].

TO 1 DECIMAL PLACE ±.2  
 TO 2 DECIMAL PLACES ±.10  
 AS ANGLES ±

ISSUE	DATE
A	03/15/01
B	03/27/01
C	10/02/08

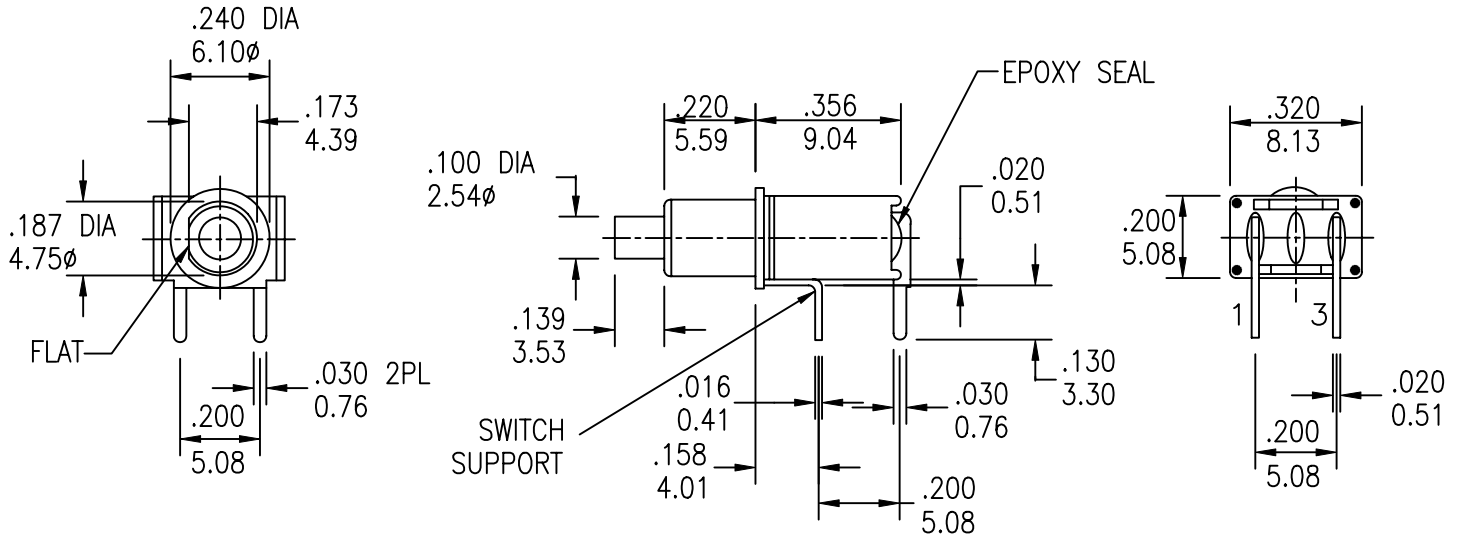

MODEL NO.	SWITCHING POSITION	
TS21A	OFF	MOM
CONN. TERMS	OPEN	1-3
SCHEMATIC	SPST	

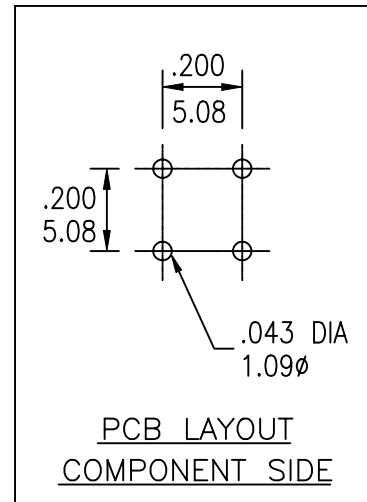

UNLESS OTHERWISE SPECIFIED, ALL DIMENSIONS ARE IN INCHES [MM].

TO 1 DECIMAL PLACE ±.2  
 TO 2 DECIMAL PLACES ±.10  
 AS ANGLES ±

ISSUE	DATE
A	03/15/01
B	03/27/01
C	10/02/08

SPECIFICATIONS

ELECTRICAL

CONTACT RATING:

SILVER: 3A @ 120 VAC OR 28 VDC, 1A @ 250 VAC

GOLD: 0.4 VA MAX. @ 20 V MAX. (AC OR DC)

CONTACT RESISTANCE: 20 MILLIOHMS MAX.

INSULATION RESISTANCE: 1,000 MEGOHMS MIN. AT 500 VDC

DIELECTRIC STRENGTH: 1,000 VRMS

MECHANICAL

LIFE: 60,000 CYCLES

ENVIRONMENTAL

OPERATING TEMPERATURE: -30°C TO +85°C

MATERIAL

CASE: DAP, UL94V-0

HOUSING: STAINLESS STEEL

ACTUATOR: THERMOPLASTIC POLYESTER

BUSHING: BRASS, NICKEL PLATED

SUPPORT: BRASS, TIN PLATED

CONTACT/TERMINALS: COPPER ALLOY, SILVER OR GOLD PLATED

REGULATORY

UL AND CANADA RECOGNIZED COMPONENT. UL/CUL FILE NO. E173084.

PART NUMBER BUILDER:

SERIES	MODEL NO.	ACTUATOR CAP	CAP COLOR	BUSHING	TERMINATION	CONTACT PLATING	SEAL
SRSP -	<input type="text" value=""/> <input type="text" value=""/> <input type="text" value=""/> <input type="text" value=""/> <input type="text" value=""/>	- <input type="text" value=""/>	<input type="text" value=""/>	<input type="text" value=""/>	<input type="text" value=""/>	<input type="text" value=""/>	<input type="text" value=""/>
	TS21A	BLANK CV CV1 F22A	BLANK 1 - BLUE 2 - RED 3 - BLACK 4 - BROWN 5 - GREEN 6 - WHITE 7 - GRAY 8 - ORANGE 9 - YELLOW 0 - VIOLET	S (STD - THD) U (NON-THD) T (NON-THD) V (THD) V1 (NON-THD)	C (PC MOUNT)	Q (SILVER) R (GOLD)	BLANK E (EPOXY)



TITLE: PUSHBUTTON SWITCH		PART NO: SRSP-TS21A-XXXXXX			
DATE: 03/05/01	DRAWN: RB	CHKD: JF	SCALE: N/A	SHEET: 2 OF 4	

UNLESS OTHERWISE SPECIFIED, ALL DIMENSIONS ARE IN INCHES [MM].

TO 1 DECIMAL PLACE ±.2  
 TO 2 DECIMAL PLACES ±.10  
 AS ANGLES ±

ISSUE	DATE
A	03/15/01
B	03/27/01
C	10/02/08

ACTUATOR OPTIONS

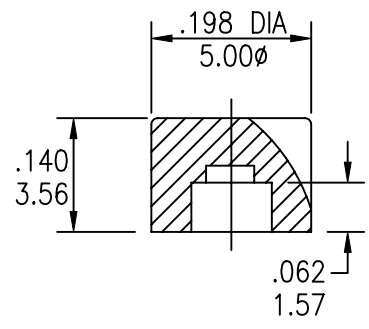

CV

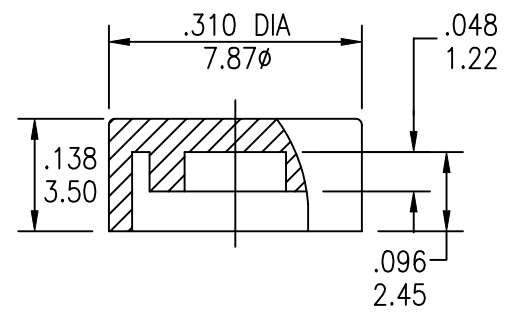

CV1

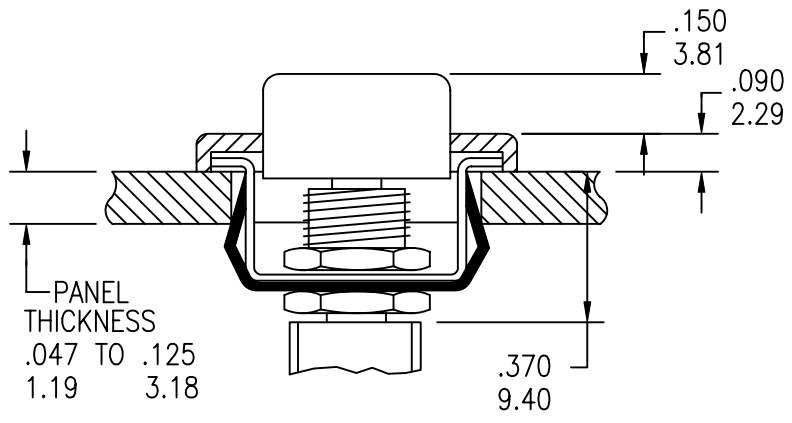

F22A

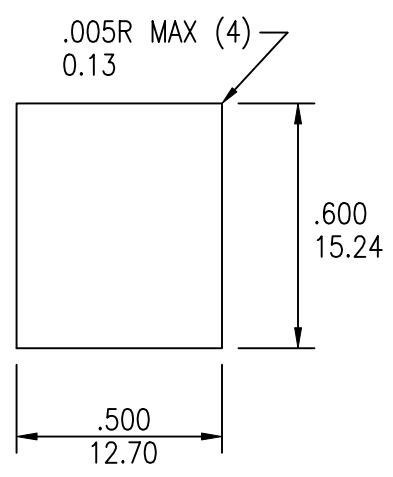
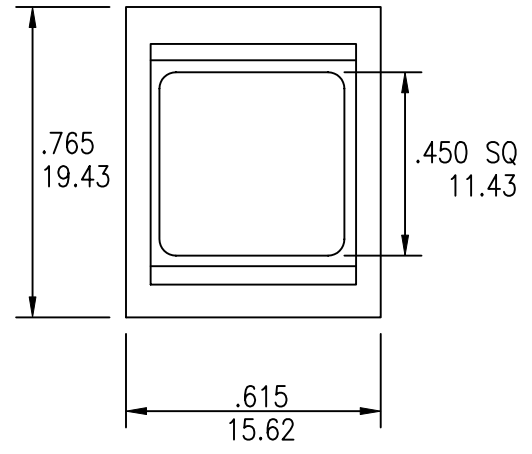

UNLESS OTHERWISE SPECIFIED, ALL DIMENSIONS ARE IN INCHES [MM].

TO 1 DECIMAL PLACE ±.2  
 TO 2 DECIMAL PLACES ±.10  
 AS ANGLES ±

ISSUE	DATE
A	03/15/01
B	03/27/01
C	10/02/08

BUSHING OPTIONS

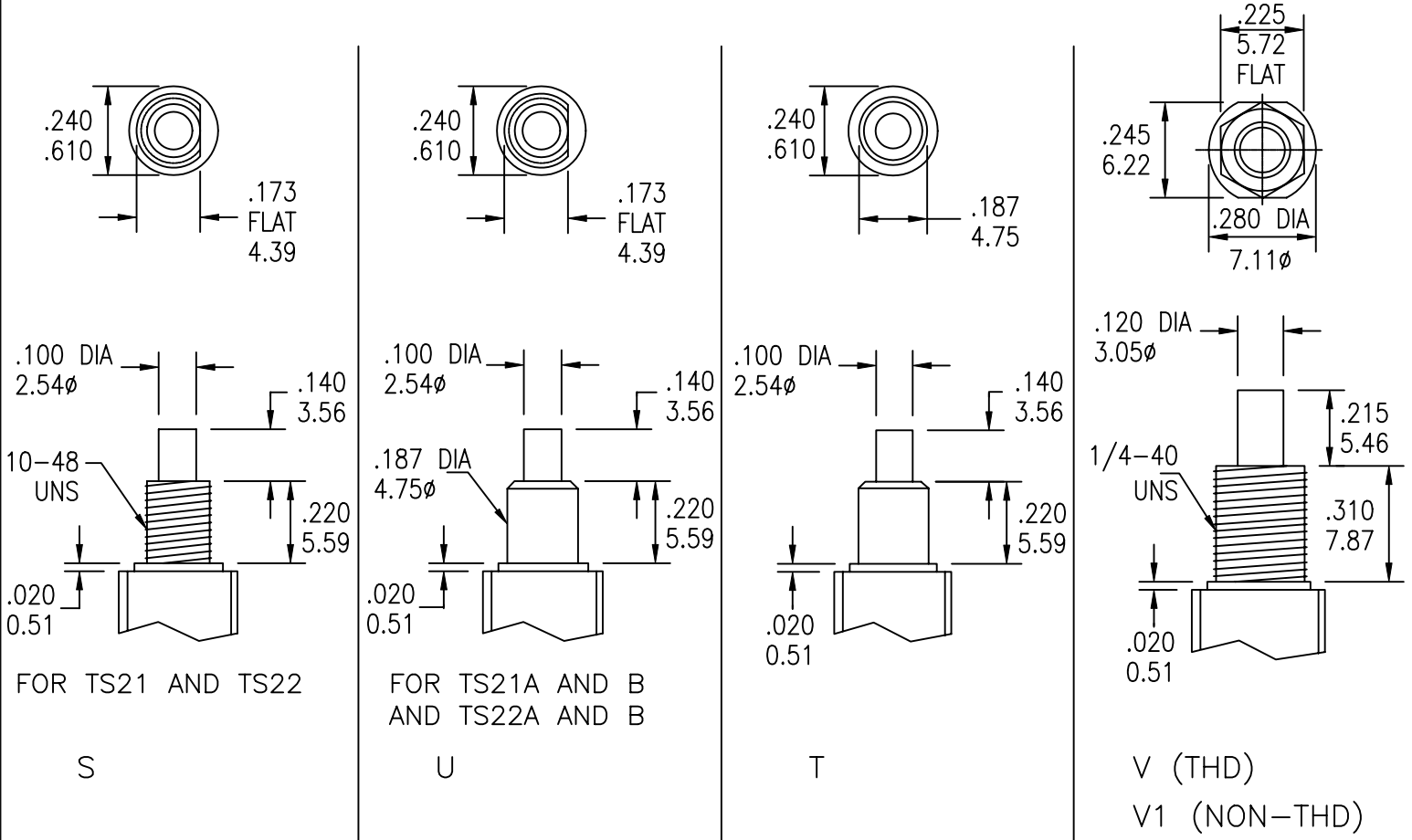

TERMINATION

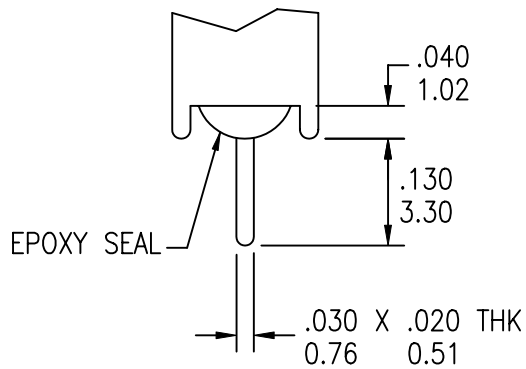

C (PC MOUNT)



TITLE: PUSHBUTTON SWITCH		PART NO: SRSP-TS21A-XXXXXX	
DATE: 03/05/01	DRAWN: RB	CHKD: JF	SCALE: N/A
		SHEET: 4 OF 4	