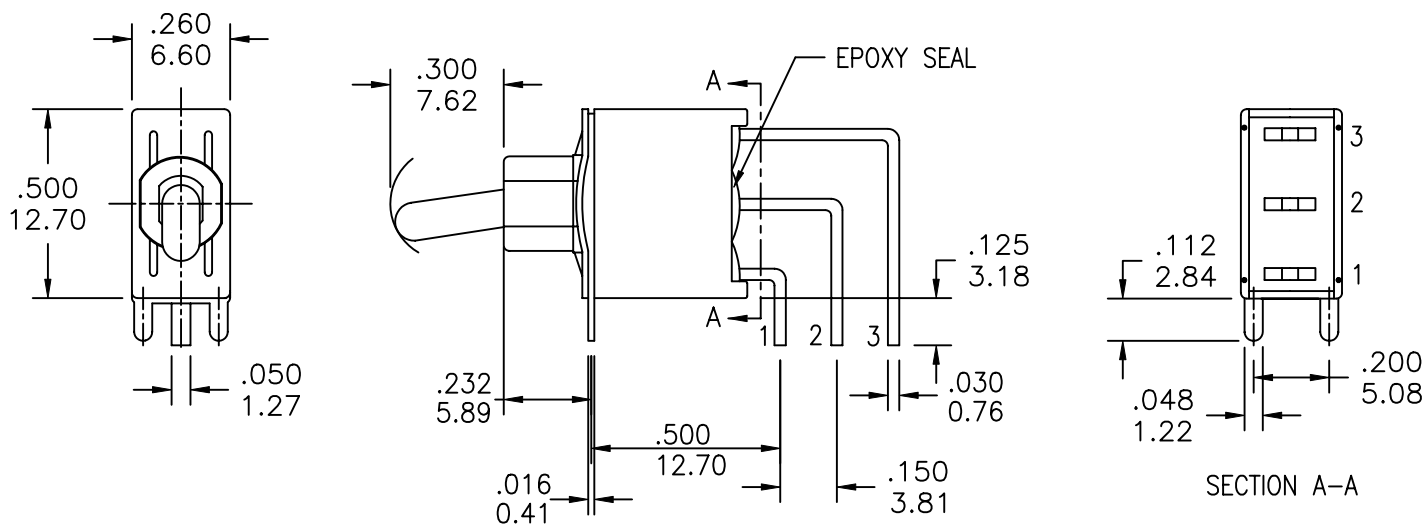

1

2

3

4

COMPONENT
SPECIFICATIONUSE OR REPRODUCTION OF THIS DRAWING FOR THE PURPOSE OF MANUFACTURING THIS
ARTICLE OR ANY ARTICLES SHOWN FOR ANY PURPOSE IS STRICTLY PROHIBITED WITHOUT
WRITTEN PERMISSION FROM SENIOR INDUSTRIES, INC.

PART SHOWN: SRST-907-TMCQE

MODEL NO.	SWITCHING POSITION		
907	ON	NONE	ON
907A	ON	NONE	MOM
908	ON	OFF	ON
908A	MOM	OFF	MOM
908B	ON	OFF	MOM
CONN. TERMS	2-3	OPEN	2-1
SCHEMATIC	SPDT		

PC MOUNT

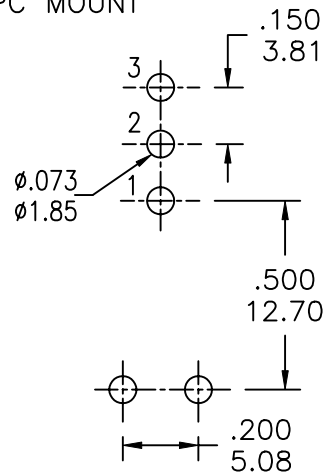
PCB LAYOUT
COMPONENT SIDE
(TOLERANCE = ± 0.1)

DESIGNED:			SYM.	DATE	DESCRIPTION OF REVISIONS	DRAWN	APPD.
DRAWN:	GAT	01/12/10		01.12.10	NEW	GAT	JF
CHECKED:	GAT	01/12/10		.	.		
APPROVED:	JF	01/12/10		.	.		

3RD ANGLE

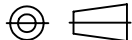

UNIT:

IN/mm

SCALE:

1:1

REV.

A

SENIOR
INDUSTRIES, INC.

TOLERANCE:

TO 2 DECIMAL PLACE: ± 0.1 TO 3 DECIMAL PLACES: ± 0.005

AS ANGLES:

PART NO:

SEE CHART

TITLE:

SRST 907/908 VERTICAL RIGHT
ANGLE SEALED TOGGLE SWITCH

SHEET:

1 OF 3

COMPONENT
SPECIFICATIONUSE OR REPRODUCTION OF THIS DRAWING FOR THE PURPOSE OF MANUFACTURING THIS
ARTICLE OR ANY ARTICLES SHOWN FOR ANY PURPOSE IS STRICTLY PROHIBITED WITHOUT
WRITTEN PERMISSION FROM SENIOR INDUSTRIES, INC.SPECIFICATIONSELECTRICAL

CONTACT RATING:

SILVER: 5A @ 120 VAC OR 28 VDC, 2A @ 250 VAC

GOLD: 0.4 VA MAX. @ 20 V MAX. (AC OR DC)

CONTACT RESISTANCE: 10 MILLIOHMS MAX. @ 2-4 VDC

INSULATION RESISTANCE: 1,000 MEGOHMS MIN. AT 500 VDC

DIELECTRIC STRENGTH: 1,000 VRMS

MECHANICAL

LIFE: 30,000 CYCLES

ENVIRONMENTAL

OPERATING TEMPERATURE: -30°C TO +85°C

MATERIAL

CASE: GLASS FILLED NYLON 6/6, UL94V-0

BUSHING: GLASS FILLED NYLON 6/6, UL94V-0

ACTUATOR: BRASS, CHROME PLATED WITH STD INTERNAL O-RING SEAL

SWITCH SUPPORT: BRASS OR STEEL, TIN PLATED







SWITCH SUPPORT RETAINER: STAINLESS STEEL



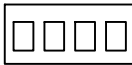

CONTACT/TERMINALS: COPPER ALLOY, SILVER OR GOLD PLATED

REGULATORY

UL AND CANADA RECOGNIZED COMPONENT. UL/CUL FILE NO. E173084.

PART NUMBER BUILDER:

SERIES	MODEL NO.	ACTUATOR	BUSHING	TERMINATION	CONTACT PLATING	SEAL
SRST -		- 				
	907 907A 908 908A 908B	S T (STD)	M (STD NON-THD)	C (VERTICAL RIGHT ANGLE, PC MOUNT) CN (VERTICAL RIGHT ANGLE, PC MOUNT, SNAP-IN)	Q (SILVER) R (GOLD)	BLANK E (EPOXY)

DESIGNED:			SYM.	DATE	DESCRIPTION OF REVISIONS	DRAWN	APPD.
				01.12.10	NEW	GAT	JF
DRAWN:	GAT	01/12/10		.			
CHECKED:	GAT	01/12/10		.			
APPROVED:	JF	01/12/10		.			

3RD ANGLE

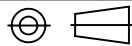

UNIT:

IN/mm

SCALE:

REV.

A

**SENIOR
INDUSTRIES, INC.**

TOLERANCE:

TO 2 DECIMAL PLACE: ±

TO 3 DECIMAL PLACES: ±

AS ANGLES: ±

SHEET:

PART NO:

SEE CHART

TITLE:

SRST 907/908 VERTICAL RIGHT
ANGLE SEALED TOGGLE SWITCH

2 OF 3

1

2

3

4

COMPONENT SPECIFICATION

USE OR REPRODUCTION OF THIS DRAWING FOR THE PURPOSE OF MANUFACTURING THIS ARTICLE OR ANY ARTICLES SHOWN FOR ANY PURPOSE IS STRICTLY PROHIBITED WITHOUT WRITTEN PERMISSION FROM SENIOR INDUSTRIES, INC.

A

ACTUATOR OPTIONS

BUSHING OPTIONS

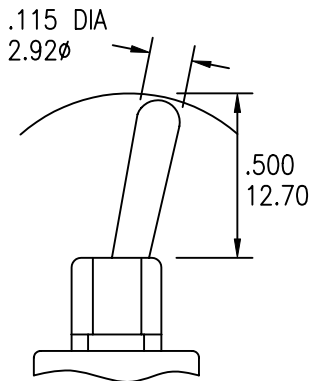

S

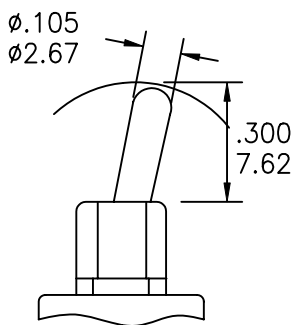

T (STANDARD)

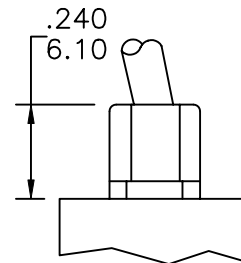

M (STD NON-THD)

B

TERMINATION OPTIONS

PC MOUNT

PC MOUNT, SNAP-IN

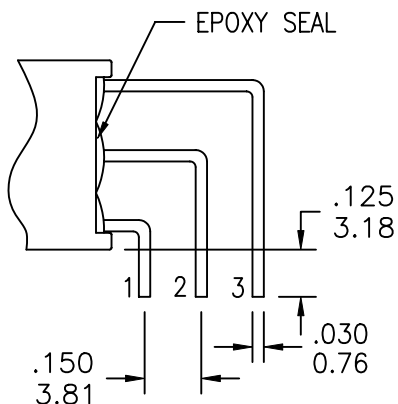

C THK .050 [1.27]

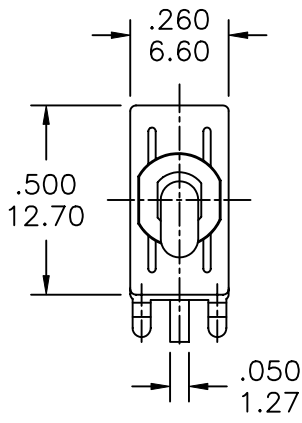

CN

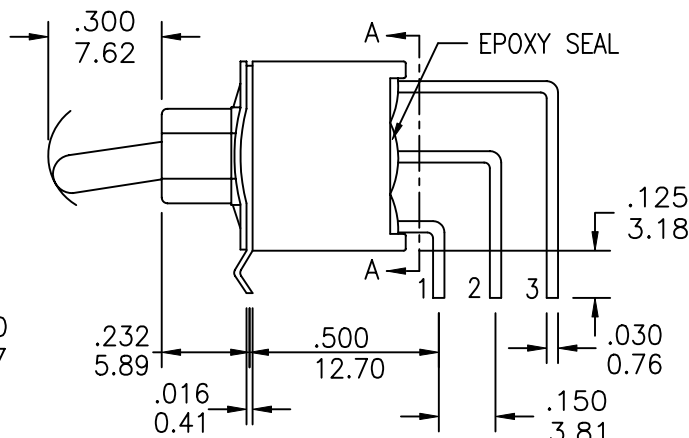

C

D

NOTE: OPTIONAL TOGGLE CAP AVAILABLE.

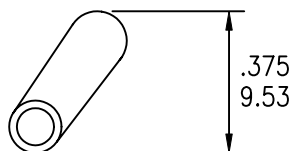

E

DESIGNED:			SYM.	DATE	DESCRIPTION OF REVISIONS	DRAWN	APPD.
DRAWN:	GAT	01/12/10	△	01.12.10	NEW	GAT	JF
CHECKED:	GAT	01/12/10	△	.			
APPROVED:	JF	01/12/10	△	.			

3RD ANGLE		UNIT:	IN/mm	SCALE:	1:1	REV.	A
-----------	--	-------	-------	--------	-----	------	---



TOLERANCE:	PART NO:	SEE CHART
TO 2 DECIMAL PLACE: ±.01	TITLE:	SRST 907/908 VERTICAL RIGHT ANGLE SEALED TOGGLE SWITCH
TO 3 DECIMAL PLACES: ±.005		
AS ANGLES:		
SHEET:		3 OF 3