

UNLESS OTHERWISE SPECIFIED, ALL DIMENSIONS ARE IN INCHES [MM].

TO 1 DECIMAL PLACE ±.2
 TO 2 DECIMAL PLACES ±.10
 AS ANGLES ±

ISSUE	DATE
A	03/07/01
B	08/28/03

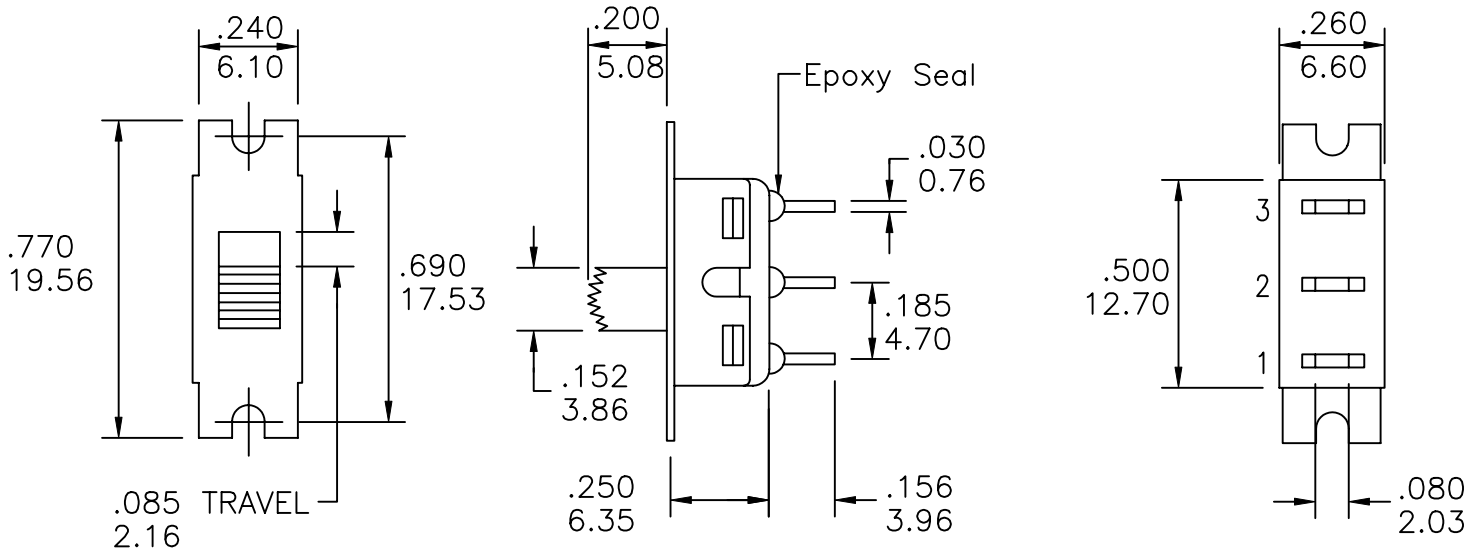

SHOWN WITH MOUNTING FLANGE

FOR PC MOUNT TERMINATION ONLY.

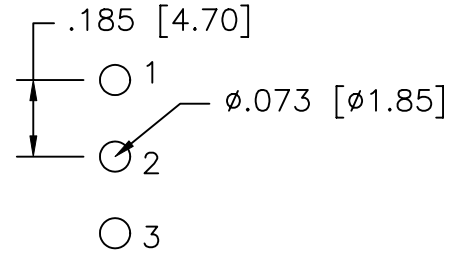

PCB LAYOUT

MODEL NO.	SWITCHING FUNCTION		
TS13	ON	NONE	ON
TS13A	ON	OFF	ON
TS13B	ON	NONE	MOM
CONN. TERMS	2-1	OPEN	2-3
SCHEMATIC	SPDT		

NON-SHORTING TYPE

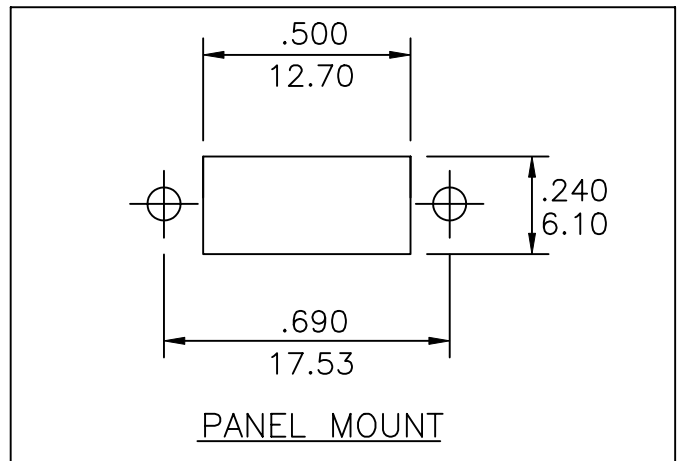

PANEL MOUNT

UNLESS OTHERWISE SPECIFIED, ALL DIMENSIONS ARE IN INCHES [MM].

TO 1 DECIMAL PLACE ±.2
 TO 2 DECIMAL PLACES ±.10
 AS ANGLES ±

ISSUE	DATE
A	03/07/01
B	08/28/03

SPECIFICATIONS

ELECTRICAL

CONTACT RATING:

SILVER: 5A @ 120 VAC OR 28 VDC, 2A @ 250 VAC
 GOLD: 0.4 VA MAX. @ 20 V MAX. (AC OR DC)

CONTACT RESISTANCE: 10 MILLIOHMS MAX.
 INSULATION RESISTANCE: 1,000 MEGOHMS MIN. AT 500 VDC
 DIELECTRIC STRENGTH: 1,000 VRMS

MECHANICAL

LIFE: 30,000 CYCLES

ENVIRONMENTAL







OPERATING TEMPERATURE: -30°C TO +85°C

MATERIAL

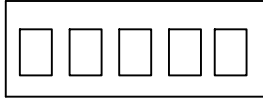
CASE: DAP, UL94V-0
 HOUSING: STAINLESS STEEL
 ACTUATOR: NYLON
 CONTACTS/TERMINALS: COPPER ALLOY, SILVER OR GOLD PLATED

REGULATORY

UL AND CANADA RECOGNIZED COMPONENT. UL/CUL FILE NO. E173084.

SERIES	MODEL NO.	ACTUATOR	COLOR	TERMINATION	CONTACT PLATING	SEAL	MOUNTING FLANGE
SRS							
	TS13 TS13A TS13B	STANDARD= S OR BLANK A B C	1 BLUE 2 RED 3 OR BLANK=BLACK 4 BROWN 5 GREEN 6 WHITE 7 GRAY 8 ORANGE 9 YELLOW 0 VIOLET		Q SILVER R GOLD B SOLDER LUG C PC MOUNT D QUICK CONNECT D1 WIRE WRAP (.750) D2 WIRE WRAP (.964) D3 WIRE WRAP (.425) D4 WIRE WRAP (1.062)	BLANK E EPOXY	BLANK F



TITLE: SRS TS13/13A/13B SLIDE SWITCHES			PART NO: SEE CHART		
DATE: 11/28/00	DRAWN: RB	CHKD:	SCALE: N/A	SHEET: 2 OF 3	

UNLESS OTHERWISE SPECIFIED, ALL DIMENSIONS ARE IN INCHES [MM].

TO 1 DECIMAL PLACE ±.2
 TO 2 DECIMAL PLACES ±.10
 AS ANGLES ±

ISSUE	DATE
A	03/07/01
B	08/28/03

ACTUATOR OPTIONS

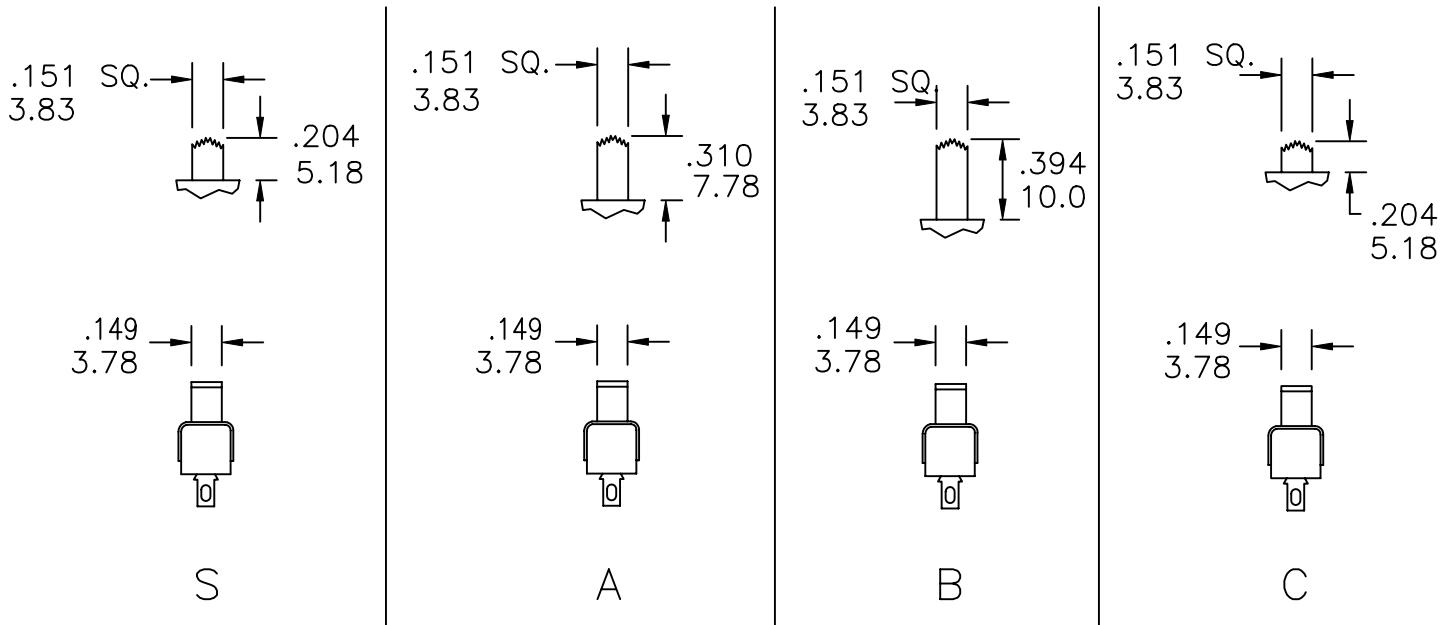

TERMINATION OPTIONS

SOLDER LUG

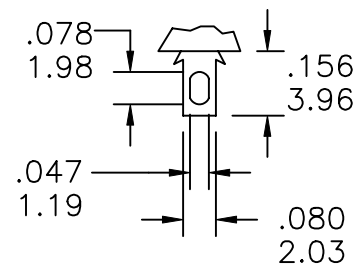

B

PC MOUNT

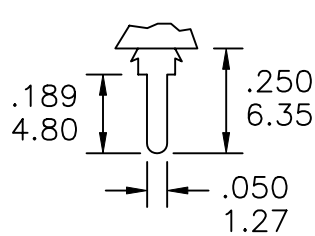

C

QUICK CONNECT

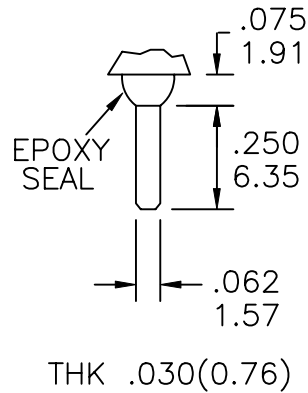

D

WIRE WRAP

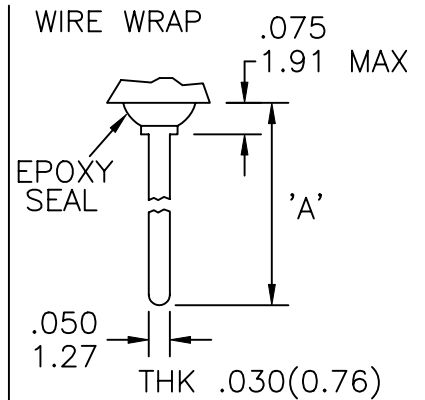

	'A'
D1	.750(19.05)
D2	.964(24.48)
D3	.425(10.80)
D4	1.062(26.97)